

Jeep

GRAND CHEROKEE

2014-2017
(4th Generation)
SERVICE MANUAL



VEHICLE INFORMATION > INTERNATIONAL VEHICLE CONTROL AND DISPLAY SYMBOLS > DESCRIPTION > DESCRIPTION

FCA US LLC uses international symbols to identify various systems on the vehicle.

The graphic symbols illustrated are used to identify various instrument controls, vehicle controls and service information references. The symbols correspond to the controls and displays that are located on the instrument panel and throughout the vehicle.

Fig 1: Information Symbols

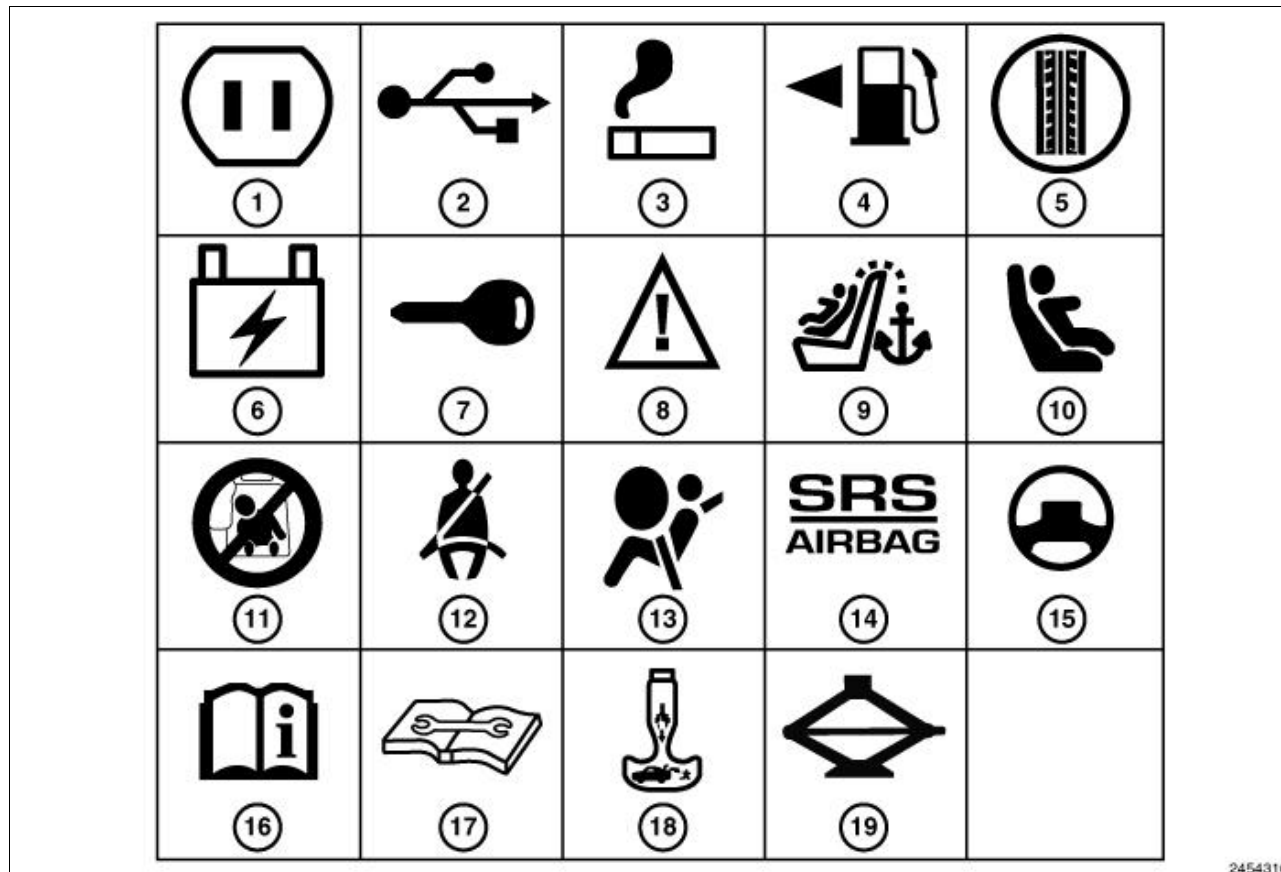

2454316











































Courtesy of CHRYSLER GROUP, LLC

INTERNATIONAL INFORMATION SYMBOL IDENTIFICATION

SYMBOL	DESCRIPTION	SYMBOL	DESCRIPTION
1	115-Volt Power Inverter	11	Side Airbag
2	USB Connector	12	Seat Belt
3	Lighter	13	Airbag
4	Fuel Fill Side	14	Supplemental Restraint System

5	Spare Tire Winch	15	Power Steering Fluid
6	Fuse	16	See Owner's Manual
7	Key Activate (Power Outlet)	17	See Appropriate Service Information
8	Warning	18	Emergency Release Handle
9	Child Seat Tether Anchor	19	Jack/Jack Tools Location
10	Lower Anchors and Tether for Children (Latch)		

Fig 2: Indicator Symbols

			ESP BAS		
①	②	③	④	⑤	⑥
					
⑦	⑧	⑨	⑩	⑪	⑫
(ABS)	(RBS)				
⑬	⑭	⑮	⑯	⑰	⑱
					
⑲	⑳	㉑	㉒	㉓	㉔
					
㉕	㉖	㉗	㉘	㉙	㉚
	BRAKE (!)	AWD!	4WD!	4 LOW	TOW/ HAUL
㉛	㉜	㉝	㉞	㉟	㊱
SERV 4WD	SVC 4WD	CRUISE	BRAKE	(!)	SWAY BAR
㊲	㊳	㊴	㊵	㊶	㊷
FRONT 	REAR 		(!)(P)	 OFF	
㊸	㊹	㊺	㊻	㊼	㊽
					
㊾	㊿	51	52	53	54
					
55	56	57	58		

0004002550





































































Courtesy of CHRYSLER GROUP, LLC

INTERNATIONAL INDICATOR SYMBOL IDENTIFICATION

SYMBOL	DESCRIPTION	SYMBOL	DESCRIPTION
1	Electronic Speed Control	30	Door Ajar

2	Hill Descent Control	31	Liftgate Open
3	Traction Control	32	Brake System Warning Parking Brake
4	Electronic Stability Program/Brake System Assist System	33	All Wheel Drive
5	Security Indicator	34	Four Wheel Drive
6	Turn Signals	35	Four Wheel Drive Low
7	Water In Fuel	36	Tow/Haul
8	Low Fuel	37	Service Four Wheel Drive
9	Side Airbag	38	Service Four Wheel Drive
10	Seat Belt Reminder	39	Cruise Indicator
11	Airbag Warning Light	40	Brake System Warning Parking Brake
12	Passenger Airbag Off	41	Tire Pressure Monitor
13	Failure Of Anti-Lock Braking System	42	Sway Bar Disconnect Indicator
14	HEV Brake Regenerative Light	43	Front Axle Lock
15	Electronic Throttle Control	44	Rear Axle Lock
16	HEV Service Light	45	Park ASSIST Indicator
17	Engine Oil	46	Park Brake Indicator
18	Battery Charging	47	Electronic Stability Control/Traction Control Off
19	Glow Plug/Intake Air Heated	48	Trailer Brake System Off
20	Power Steering Fluid	49	Diesel Exhaust Fluid
21	Engine Coolant Temperature	50	Coolant Level
22	Malfunction Indicator Light	51	Fuel Cap
23	Transmission Oil Temperature Light	52	EPS (Electric Power Steering)
24	Diesel Exhaust Brake	53	Icy Road Condition
25	High Beam	54	Electric Vehicle Plug In State
26	Front Fog Light	55	Vehicle Theft Alarm
27	Rear Fog Light	56	Stored Warnings
28	Cargo Lamp	57	Service ETC
29	Exterior Bulb Failure	58	Electric Vehicle System Service

Fig 3: Control Symbols

							
1	2	3	4	5	6	7	8
							
9	10	11	12	13	14	15	16
							
17	18	19	20	21	22	23	24
			CRUISE				
25	26	27	28	29	30	31	32
							
33	34	35	36	37	38	39	40
							
41	42	43	44	45	46	47	48
							
49	50	51	52	53	54	55	56
							
57	58	59	60	61	62	63	64
AWD!	4WD!	2WD	4WD LOW	4WD LOCK	4WD AUTO	FRONT	REAR
65	66	67	68	69	70	71	72
				AXLE LOCK		ESC OFF	
73	74	75	76	77	78	79	80

2454400

Courtesy of CHRYSLER GROUP, LLC

INTERNATIONAL CONTROL SYMBOL IDENTIFICATION

SYMBOL	DESCRIPTION	SYMBOL	DESCRIPTION	SYMBOL	DESCRIPTION
1	Rear Window Wiper	28	Cruise Indicator	55	Convertible Top Down

2	Rear Window Intermittent Wiper	29	Hill Descent Control	56	Convertible Top Up
3	Rear Window Washer	30	Park Assist Off	57	Door Lock
4	Rear Window Defrost	31	Electronic Stability Program/Brake System Assist System	58	Window Lift
5	Heated Mirror	32	Park Brake Release	59	Convertible 4 Window Down
6	Turn Signals	33	Adjustable Headlights	60	Window Lock
7	Adjustable Pedals	34	Low Beam	61	Power Rear Window
8	Horn	35	Front Fog Light	62	Voice Recognition Button
9	Windshield Wiper Intermittent	36	Rear Fog Light	63	Uconnect™ Button
10	Windshield Washer	37	Cargo Lamp	64	Sway Bar Disconnect
11	Windshield Washer Fluid Level	38	Hazard Lights	65	All Wheel Drive
12	Windshield Electrically Heated	39	115-Volt Power Inverter	66	Four Wheel Drive
13	Windshield Defrost	40	Key Activate (Power Outlet)	67	Two Wheel Drive
14	Windshield Wiper And Washer	41	Exterior Bulb Failure	68	Four Wheel Drive Low
15	Ventilating Fan	42	Master Lighting Switch	69	Four Wheel Drive Lock
16	Air Conditioning	43	Dome Light	70	Four Wheel Drive Auto
17	Upper Air Outlet	44	Park Lights	71	Front Axle Lock
18	Upper And Lower Air Outlet	45	Instrument Panel Illumination	72	Rear Axle Lock
19	Lower Air Outlet	46	Electronic Stability Program Off	73	EVIC Menu
20	Defrost And Lower Air Outlet	47	Diesel Exhaust Brake	74	Navigation Button
21	Heated Seat Low	48	Overdrive Off	75	Step
22	Heated Seat High	49	Hood Release	76	Reset

23	Ventilated Seat	50	Trunk/Deck Release	77	Axle Lock Button
24	Recirculation	51	Door Ajar	78	Traction Control Off
25	Heated Steering Wheel	52	Liftgate Release	79	Electronic Stability Control Off
26	Passenger Air Bag Off	53	Sliding Door	80	Trailer Brakes
27	Electronic Speed Control	54	Sliding Door		

VEHICLE INFORMATION > INTERNATIONAL VEHICLE CONTROL AND DISPLAY SYMBOLS > DESCRIPTION > DESCRIPTION > ENGINE COMPARTMENT

Fig 1: International Symbols

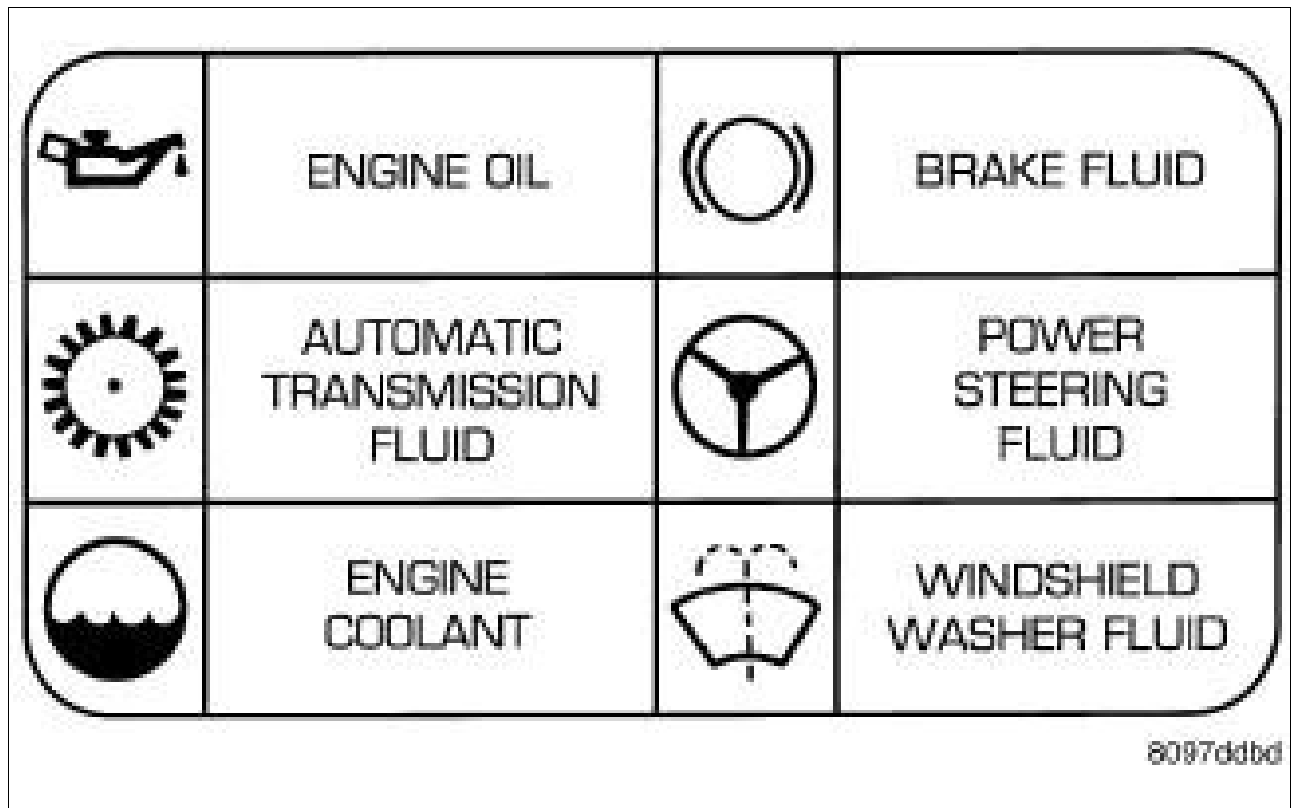

Courtesy of CHRYSLER GROUP, LLC

The graphic symbols illustrated are used to identify engine compartment lubricant and fluid inspection and fill locations. The symbols correspond to the caps located within the engine compartment.

VEHICLE INFORMATION > LABEL, VEHICLE EMISSION CERTIFICATION INFORMATION (VECI) > DESCRIPTION > DESCRIPTION

Fig 1: VECI Label Location

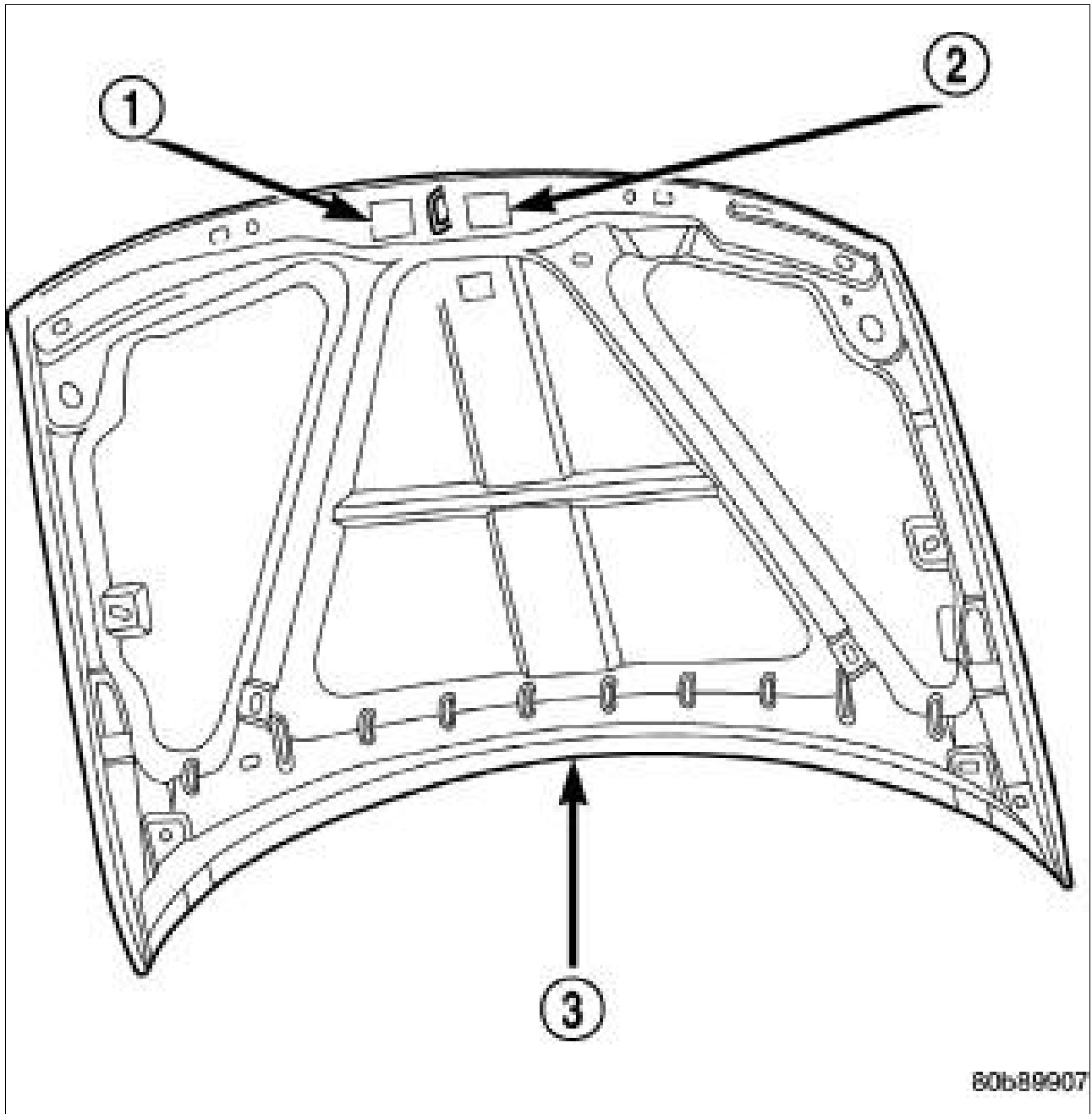

80b89907

Courtesy of CHRYSLER GROUP, LLC

1 - VECI LABEL (CANADIAN)

2 - VECI LABEL

3 - HOOD



NOTE:

The Vehicle Emission Control Information (VECI) label(s) must be in place for the life of the vehicle. When replacing the component in which the VECI label is adhered, a new VECI

label must also be adhered to the new component.

All vehicles are equipped with a combined VECI label(s). The label is located in the engine compartment on the vehicle hood. Two labels are used for vehicles built for sale in the country of Canada.

The VECI label(s) contain the following:

- Engine family and displacement
- Evaporative family
- Certification application
- Spark plug and gap

VEHICLE INFORMATION > VEHICLE CERTIFICATION LABEL > DESCRIPTION > DESCRIPTION

Fig 1: Vehicle Certification Label - Typical



Courtesy of CHRYSLER GROUP, LLC

A vehicle certification label is attached to every FCA US LLC vehicle. The label certifies that the vehicle conforms to all applicable Federal Motor Vehicle Standards. The label also lists:

- Month and year of vehicle manufacture.
- Gross Vehicle Weight Rating (GVWR). The gross front and rear axle weight ratings (GAWR's) are based on a minimum rim size and maximum cold tire inflation pressure.
- Vehicle Identification Number (VIN).
- Type of vehicle.
- Type of rear wheels.
- Bar code.

- Month, Day and Hour (MDH) of final assembly.
- Paint and Trim codes.
- Country of origin.

The label is located on the driver-side door shut-face.

VEHICLE INFORMATION > VEHICLE IDENTIFICATION NUMBER > DESCRIPTION > DESCRIPTION

Fig 1: Vehicle Identification Number (VIN) Label

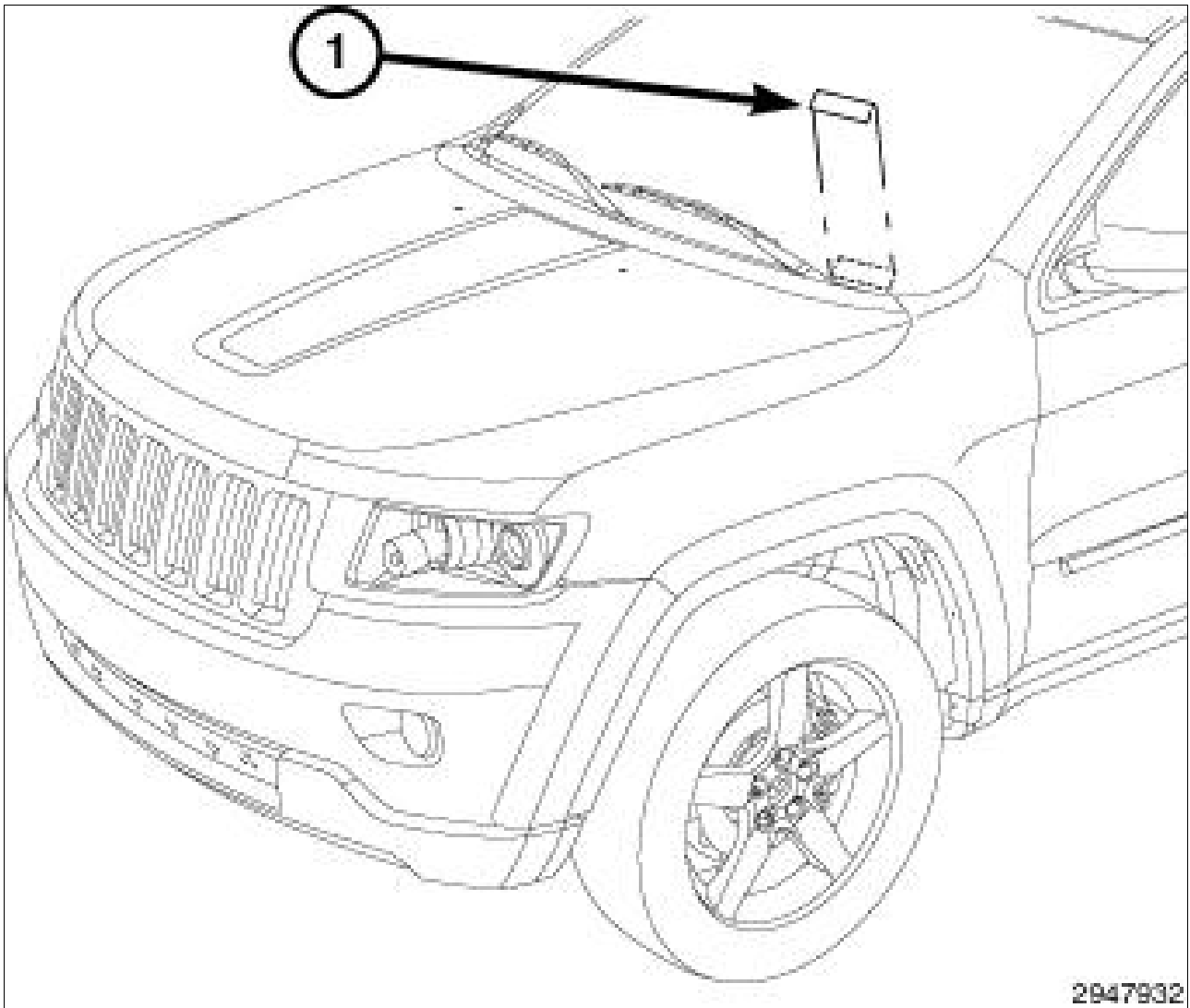

Courtesy of CHRYSLER GROUP, LLC

The Vehicle Identification Number (VIN) label (1) is attached to the top left side of the instrument panel. The VIN contains 17 characters that provide data concerning the vehicle. Refer to the decoding chart below to determine the identification of a vehicle.

To protect the consumer from theft and possible fraud the manufacturer is required to include a Check

Digit at the ninth position of the Vehicle Identification Number. The check digit is used by the manufacturer and government agencies to verify the authenticity of the vehicle and official documentation. The formula to use the check digit is not released to the general public.

VEHICLE INFORMATION > VEHICLE IDENTIFICATION NUMBER > DESCRIPTION > DESCRIPTION > POSITIONS 1 - 3: WORLD MANUFACTURER IDENTIFIER

1	2	3	MANUFACTURER	VEHICLE TYPE
1	C	4	Chrysler Group LLC (USA)	MPV

VEHICLE INFORMATION > VEHICLE IDENTIFICATION NUMBER > DESCRIPTION > DESCRIPTION > POSITION 4: BRAKE SYSTEM & GVWR

Brake System	GVWR Range		Active Belts, Air Bags	Active Belts, Air Bags, Side Bags-Front Row	Active Belts, Air Bags, Side Bags-All Rows	Active Belts, No Air Bags	Active Belts, GVWR > 10,000 lbs.
	Pounds	Kilograms					
Hydraulic	6001 - 7000	(2722 - 3175 KG)	C	J	R	-	-

VEHICLE INFORMATION > VEHICLE IDENTIFICATION NUMBER > DESCRIPTION > DESCRIPTION > POSITIONS 5 - 7:

Define the following: Brand, Marketing Name, Drive Wheels, Cab/Body Type, Drive Position, and Price Series.

FWD			AWD			BODY TYPE	POSITION	SERIES
J	E	A	J	F	A			
J	E	B	J	F	B	Limited		
J	E	C	J	F	C	Overland		
-	-	-	J	F	D	SRT8		
J	E	J	J	F	J	Summit		
J	E	E	J	F	E	Right Hand Drive	Laredo	
-	-	-	J	F	F		Limited	
-	-	-	J	F	G		Overland	

-	-	-	J	F	H			SRT8
-	-	-	J	F	K			Summit

VEHICLE INFORMATION > VEHICLE IDENTIFICATION NUMBER > DESCRIPTION > DESCRIPTION > POSITION 8: ENGINE

Code	Displacement	Cylinders	Fuel	Turbo	Sales Codes
M	3.0 Liter	6	Diesel	Yes	EXF
8	3.0 Liter	6	Gasoline	No	EHD
G	3.6 Liter	6	Gasoline	No	ERB
T	5.7 Liter	8	Gasoline	No	EZH
J	6.4 Liter	8	Gasoline	No	ESG

VEHICLE INFORMATION > VEHICLE IDENTIFICATION NUMBER > DESCRIPTION > DESCRIPTION > POSITION 9: CHECK DIGIT

0 through 9 or X

VEHICLE INFORMATION > VEHICLE IDENTIFICATION NUMBER > DESCRIPTION > DESCRIPTION > POSITION 10: MODEL YEAR

G = 2016

VEHICLE INFORMATION > VEHICLE IDENTIFICATION NUMBER > DESCRIPTION > DESCRIPTION > POSITION 11: ASSEMBLY PLANT

Code	Plant
C	Jefferson North Assembly

VEHICLE INFORMATION > VEHICLE IDENTIFICATION NUMBER > DESCRIPTION > DESCRIPTION > POSITION 12 - 17: PLANT SEQUENCE NUMBER

A six digit number assigned by assembly plant.

CAPACITIES AND RECOMMENDED FLUIDS > SPECIFICATIONS > SPECIFICATIONS

ENGINE

Description	Type	Capacities	
		U.S.	Metric
Cooling System			
(1) Engine Coolant (3.0L Diesel Engines)	We recommend you use MOPAR® Antifreeze/Coolant 10 Year/150, 000 Mile Formula OAT (Organic Additive Technology).	12.0 Quarts	11.4 Liters
(1) Engine Coolant (3.0L/3.6L Gas Engines)	We recommend you use MOPAR® Antifreeze/Coolant 10 Year/150, 000 Mile Formula OAT (Organic Additive Technology).	10.4 Quarts	9.9 Liters
(1) Engine Coolant (5.7L Engines without Trailer Tow Package)	We recommend you use MOPAR® Antifreeze/Coolant 10 Year/150, 000 Mile Formula OAT (Organic Additive Technology).	15.4 Quarts	14.6 Liters
(1) Engine Coolant (5.7L Engines with Trailer Tow Package)	We recommend you use MOPAR® Antifreeze/Coolant 10 Year/150, 000 Mile Formula OAT (Organic Additive Technology).	16.0 Quarts	15.2 Liters
(1) Engine Coolant (6.4L Engines)	We recommend you use MOPAR® Antifreeze/Coolant 10 Year/150, 000 Mile Formula OAT (Organic Additive Technology) hat meets the requirements of Material Standard MS.90032.	16.0 Quarts	15.2 Liters
Engine Oil with Filter			
Engine Oil (3.0L Diesel Engine)	We recommend you use SAE 5W-30 Synthetic Low Ash Engine Oil meeting he requirements of Material Standard MS-11106 or 9.55535- S3 and approved ACEA C3 such as MOPAR or equivalent.	8 Quarts	7.7 Liters
(2) Engine Oil (3.0L/3.6L Gas Engine- Domestic/Non-ACEA)	We recommend you use API Certified SAE 0W-20 Engine Oil, mee ing the requirements of Material Standard MS-6395 such as MOPAR, Pennzoil, and Shell Helix. Refer to your engine oil filler cap for correct SAE grade.	6 Quarts	5.6 Liters
(2) Engine Oil (3.0L/3.6L Gas Engine- ACEA Categories)	We recommend you use API Certified SAE 0W-20 engine oil, meeting the requirements of Material Standard MS-6395 or 9.55535-CR1. Refer to your engine oil filler cap for the correct SAE grade.	6 Quarts	5.6 Liters
(3) Engine Oil (5.7L Engine - Domestic/Non-ACEA)	We recommend you use API Certified SAE 5W-20 Engine Oil, mee ing the requirements of Material Standard MS-6395 such as MOPAR, Pennzoil, and Shell Helix. Refer to your engine oil filler cap for correct SAE grade.	7 Quarts	6.6 Liters
(3) Engine Oil (5.7L Engine - ACEA Categories)	We recommend you use API Certified SAE 5W-20 engine oil, meeting the requirements of Material Standard MS-6395 or	7 Quarts	6.6 Liters

	9.55535-CR1. Refer to your engine oil filler cap for the correct SAE grade.		
Engine Oil (6.4L Engine) Domestic and Export	For best performance and maximum protection under all types of operating conditions, the manufacturer only recommends full synthetic engine oils that meet the American Petroleum Institute (API) categories of SN. The manufacturer recommends the use of Pennzoil Ultra 0W-40 or equivalent MOPAR engine oil meeting the requirements of Material Standard MS-12633 for use in all operating temperatures.	7 Quarts	6.6 Liters
Engine Oil Filter (3.0L Diesel Engine)	We recommend you use MOPAR Engine Oil Filter or equivalent.	N/A	N/A
Engine Oil Filter (3.0L/3.6L Gas Engine)	We recommend you use MOPAR Engine Oil Filter or equivalent.	N/A	N/A
Engine Oil Filter (5.7L/6.4L Engine)	We recommend you use MOPAR Engine Oil Filter or equivalent.	N/A	N/A
Diesel Fuel Filter	We recommend you use MOPAR Fuel Filter. Must meet 3 micron rating. Using a fuel filter that does not meet the manufacturers filtration and water separating requirements can severely impact fuel system life and reliability.	N/A	N/A
Fuel (approximate)			
Fuel Selection (3.0L Diesel Engine)	<p>Use good quality diesel fuel from a reputable supplier in your vehicle. Federal law requires that you must fuel this vehicle with Ultra Low Sulfur Highway Diesel fuel (15 ppm Sulfur maximum) and prohibits the use of Low Sulfur Highway Diesel fuel (500 ppm Sulfur maximum) to avoid damage to the emissions control system. For most year-round service, No. 2 diesel fuel meeting ASTM specification D-975 Grade S15 will provide good performance. We recommend you use a blend of up to 5% biodiesel, meeting ASTM specification D-975 with your diesel engine. This vehicle is compatible with biodiesel blends greater than 5% but no greater than 20% biodiesel meeting ASTM specification D-7467 provided the shortened maintenance intervals are followed as directed.</p> <div style="border: 1px solid black; padding: 5px; margin-top: 10px;"> <p> NOTE:</p> <p><i>If the vehicle is exposed to extreme cold (below 20°F or -7°C), or is required to operate at colder-than-normal conditions for prolonged periods, use climatized No. 2 diesel fuel or dilute the No. 2 diesel fuel with 50% No. 1 diesel fuel. This will provide better protection from fuel gelling</i></p> </div>	24.6 Gallons	93.1 Liters

	<i>or wax-plugging of the fuel filters.</i>		
Fuel Selection (3.0L Diesel Engine - Europe)	50 Cetane or higher (Less than 10 ppm Sulfur)	24.6 Gallons	93 Liters
Fuel Selection (3.0L/3.6L Gas Engine)	87 Octane, 0-15% Ethanol.	25 Gallons	94 Liters
Fuel Selection (3.6L Gas Engine - Europe)	Minimum 91 Octane	25 Gallons	94 Liters
Fuel Selection (3.0L/ 3.6L Gas Engine) Flexible Fuel	Ethanol E85 (ASTM D5798)	25 Gallons	94 Liters
Fuel Selection (5.7L Engine)	89 Octane Recommended - 87 Octane Acceptable, 0-15% Ethanol.	25 Gallons	94 Liters
Fuel Selection (5.7L Engine - Europe)	Minimum 91 Octane Acceptable - 95 Octane Recommended	25 Gallons	94 Liters
Fuel Selection (6.4L Engine)	Premium Unleaded 91 Octane Only or Higher, 0-15% Ethanol.	25 Gallons	94 Liters
Diesel Exhaust Fluid (DEF)	MOPAR Diesel Exhaust Fluid (API Certified) (DEF) or equivalent that has been API Certified to the ISO 22241 standard. Use of fluids not API Certified to ISO 22241 may result in system damage.	8 Gallons	30.3 Liters
A/C Refrigerant System			
A/C Refrigerant	R-134a	1.375 Pounds	623.7 Grams
(1) System fill capacity includes heater and coolant recovery bottle filled to MAX level.			
(2) SAE 5W-30 engine oil approved to 9.55535 may be used when SAE 5W-20 engine oil is not available			
MOPAR® SAE 5W-30 engine oil approved to MS-6395 such as Pennzoil® or Shell Helix® may be used when SAE 5W-20 engine oil meeting MS-6395 is not available.			
(3) Vehicles equipped with a 5.7L engine must use SAE 5W-20 oil. Failure to do so may result in improper operation of the Fuel Saver Technology.			
 CAUTION: <i>Nominal refill capacities are shown. A variation may be observed from vehicle to vehicle due to manufacturing tolerance and refill procedure.</i>			

SPARK PLUGS

Description	Type	Gap	
		U.S.	Metric
Spark Plugs (3.0L/3.6L Engine)	We recommend you use MOPAR® Spark Plugs.	0.043 in	1.10 mm
Spark Plugs (5.7L Engine)	We recommend you use MOPAR® Spark Plugs.	0.043 in	1.10 mm
Spark Plugs (6.4L Engine)	We recommend you use MOPAR® Spark Plugs.	0.043 in	1.10 mm

TRANSMISSION

Description	Type	Capacities	
		U.S.	Metric
Automatic			
HP45 - 8 Speed	Use only Mopar® ZF 8&9 Speed ATF™ Automatic Transmission Fluid or equivalent. Failure to use the	8.98 Quarts	8.5 Liters

	correct fluid may affect the function or performance of your transmission.		
HP70 - 8 Speed	Use only Mopar® ZF 8&9 Speed ATF™ Automatic Transmission Fluid or equivalent. Failure to use the correct fluid may affect the function or performance of your transmission.	8.77 Quarts	8.3 Liters

* Dry fill capacity. Depending on type and size of internal cooler, length and inside diameter of cooler lines, or use of an auxiliary cooler, these figures may vary. Refer to the appropriate service information for the correct procedures.



CAUTION:

Nominal refill capacities are shown. A variation may be observed from vehicle to vehicle due to manufacturing tolerance and refill procedure.

TRANSFER CASE

Description	Type	Capacities	
		U.S.	Metric
MP2010	We recommend you use Automatic Transmission Fluid 3353.	1.1 Pints	0.51 Liters
MP3010	MOPAR® ATF+4 Automatic Transmission Fluid	1.4 Quarts	1.35 Liters
MP3023	MOPAR® ATF+4 Automatic Transmission Fluid	2.0 Quarts	1.9 Liters



CAUTION:

Nominal refill capacities are shown. A variation may be observed from vehicle to vehicle due to manufacturing tolerance and refill procedure.

CHASSIS

Description	Type	Capacities	
		U.S.	Metric
Axles (Front)			
195FIA FE - Front Axle	We recommend you use MOPAR GL-5 Synthetic Axle Lubricant SAE 75W-85.	0.9 Quarts	0.8 Liters
Axles (Rear)			
195RIA - Rear Axle (Aluminum)	We recommend you use MOPAR GL-5 Synthetic Axle Lubricant SAE 75W-85.	1.0 Quarts	0.9 Liters
230RIA With Electronic Limited-Slip Differential (ELSD)-Rear Axle (Aluminum)	We recommend you use MOPAR GL-5 Synthetic Axle Lubricant SAE 75W-85 with friction modifier additive.	1.4 Quarts	1.3 Liters
230RIA Without Electronic Limited-Slip Differential (ELSD) - Rear Axle (Aluminum)	We recommend you use MOPAR GL-5 Synthetic Axle Lubricant SAE 75W-85.	1.2 Quarts	1.1 Liters
Chassis Systems			
Brake Master Cylinder	We recommend you use MOPAR DOT 3 Brake Fluid, SAE J1703 should be used. If DOT 3, SAE J1703 brake fluid is not available, then DOT 4 is	N/A	N/A

	acceptable.		
(1) Power Steering Reservoir (Belt Driven Pump)	MOPAR® Power Steering Fluid +4	N/A	N/A
Power Steering Reservoir (Electric Pump)	MOPAR® Hydraulic Fluid meeting the requirements of Material Standard MS-11655	N/A	N/A
(1) If MOPAR® Power Steering Fluid +4 is not available, then MOPAR® ATF +4 Automatic Transmission Fluid, is acceptable.			

 **CAUTION:**

There is an Electro-Hydraulic Power Steering (EHPS) pump on some vehicles requiring a different fluid. Do not mix power steering fluid types. Damage may result to the power steering pump and system if any other fluid is used. The mechanical power steering pump systems on this vehicle require the use of Power Steering Fluid +4, which meets material specification MS-9602 or equivalent. The EHPS system uses fluid which meets material specification MS-11655 or equivalent. Do not overfill.

 **CAUTION:**

Nominal refill capacities are shown. A variation may be observed from vehicle to vehicle due to manufacturing tolerance and refill procedure.

FUSE - RELAY LOCATIONS AND TYPES > SPECIFICATIONS > SPECIFICATIONS

 **NOTE:**

Refer to the appropriate Wiring Application for Relay description and location information.

The Power Distribution Center is located in the engine compartment near the battery. This center contains cartridge fuses, micro fuses, relays, and circuit breakers. A description of each fuse and component may be stamped on the inside cover, otherwise the cavity number of each fuse is stamped on the inside cover that corresponds to the following chart.

POWER DISTRIBUTION CENTER

Cavity	Cartridge Fuse	Micro Fuse	Description
F03	60 Amp Yellow	-	Radiator Fan
F05	40 Amp Green	-	Compressor for Air Suspension - If Equipped
F06	40 Amp Green	-	Anti-lock Brakes/Electronic Stability Control Pump
F07	30 Amp Pink	-	Starter Solenoid
F09	30 Amp Pink	-	Diesel Fuel Heater (Diesel engine only) / Brake Vacuum Pump
F10	40 Amp Green	-	Body Controller / Exterior Lighting #2
F11	30 Amp Pink	-	Trailer Tow Electric Brake - If Equipped
F12	40 Amp Green	-	Body Controller #3 / Power Locks
F13	40 Amp Green	-	Blower Motor Front
F14	40 Amp Green	-	Body Controller #4 / Exterior Lighting #1
F17	30 Amp Pink	-	Headlamp Washer- If Equipped
F19	20 Amp Blue	-	Headrest Solenoid- If Equipped
F20	30 Amp Pink	-	Passenger Door Module
F22	20 Amp Blue	-	Engine Control Module
F23	30 Amp Pink	-	Interior Lights #1
F24	30 Amp Pink	-	Driver Door Module
F25	30 Amp Pink	-	Front Wipers

F26	30 Amp Pink	-	Anti-lock Brakes/Stability Control Module/Valves
F28	20 Amp Blue	-	Trailer Tow Backup Lights - If Equipped
F29	20 Amp Blue	-	Trailer Tow Parking Lights - If Equipped
F30	30 Amp Pink	-	Trailer Tow Receptacle - If Equipped
F32	30 Amp Pink	-	Drive Train Control Module
F34	30 Amp Pink	-	Slip Differential Control
F35	30 Amp Pink	-	Sunroof - If Equipped
F36	30 Amp Pink	-	Rear Defroster
F37	25 Amp Clear	-	Rear Blower Motor - If Equipped
F38	30 Amp Pink	-	Power Inverter 115V AC - If Equipped
F39	30 Amp Pink	-	Power Liftgate - If Equipped
F40	-	10 Amp Red	Daytime Running Lights/Headlamp Leveling
F42	-	20 Amp Yellow	Horn
F44	-	10 Amp Red	Diagnostic Port
F49	-	10 Amp Red	Integrated Central Stack / Climate Control
F50	-	20 Amp Yellow	Air Suspension Control Module - If Equipped
F51	-	15 Amp Blue	Ignition Node Module / Keyless Ignition / Steering Column Lock
F52	-	5 Amp Tan	Battery Sensor
F53	-	20 Amp Yellow	Trailer Tow - Left Turn/Stop Lights - If Equipped
F56	-	15 Amp Blue	Additional Content (Diesel engine only)
F57	-	20 Amp Yellow	NOX Sensor
F58	-	15 Amp Blue	HID Headlamps LH - If Equipped
F59	-	10 Amp Red	Purging Pump (Diesel engine only)
F60	-	15 Amp Blue	Transmission Control Module
F61	-	10 Amp Red	Transmission Control Module/PM Sensor (Diesel engine only)
F62	-	10 Amp Red	Air Conditioning Clutch
F63	-	20 Amp Yellow	Ignition Coils (Gas), Urea Heater (Diesel)
F64	-	25 Amp Clear	Fuel Injectors / Powertrain
F66	-	10 Amp Red	Sunroof / Passenger Window Switches / Rain Sensor
F67	-	15 Amp Blue	CD / DVD / Bluetooth Hands-free Module - If Equipped
F68	-	20 Amp Yellow	Rear Wiper Motor
F69	-	15 Amp Blue	Spotlight Feed - If Equipped
F70	-	20 Amp Yellow	Fuel Pump Motor
F71	-	30 Amp Green	Audio Amplifier
F72	-	10 Amp Red	PCM (If Equipped)
F73	-	15 Amp Blue	HID Headlamp RH - If Equipped
F75	-	10 Amp Red	Dual Batt Control (If Equipped)
F76	-	10 Amp Red	Anti-lock Brakes/Electronic Stability Control
F77	-	10 Amp Red	Drivetrain Control Module/Front Axle Disconnect Module
F78	-	10 Amp Red	Engine Control Module / Electric Power Steering
F80	-	10 Amp Red	Universal Garage Door Opener / Compass / Anti-Intrusion Module
F81	-	20 Amp Yellow	Trailer Tow Right Turn/Stop Lights
F82	-	10 Amp Red	Steering Column Control Module/ Cruise Control / DTV
F83	-	10 Amp Red	Fuel Door
F84	-	15 Amp Blue	Switch Bank/Instrument Cluster

F85	-	10 Amp Red	Airbag Module
F86	-	10 Amp Red	Airbag Module
F87	-	10 Amp Red	Air Suspension - If Equipped / Trailer Tow / Steering Column Control Module
F88	-	15 Amp Blue	Instrument Panel Cluster
F90/F91	-	20 Amp Yellow	Power Outlet (Rear seats) Selectable
F92	-	10 Amp Red	Rear Console Lamp - If Equipped
F93	-	20 Amp Yellow	Cigar Lighter
F94	-	10 Amp Red	Shifter / Transfer Case Module
F95	-	10 Amp Red	Rear Camera / ParkSense
F96	-	10 Amp Red	Rear Seat Heater Switch / Flashlamp Charger - If Equipped
F97	-	20 Amp Yellow	Rear Heated Seats & Heated Steering Wheel - If Equipped
F98	-	20 Amp Yellow	Front Heated Seats - If Equipped
F99	-	10 Amp Red	Climate Control / Driver Assistance Systems Module / DSRC
F100	-	10 Amp Red	Active Damping - If Equipped
F101	-	15 Amp Blue	Electrochromatic Mirror/Smart High Beams - If Equipped
F103	-	10 Amp Red	Cabin Heater (Diesel Engine Only)/Rear HVAC
F104	-	20 Amp Yellow	Power Outlets (Instrument Panel/Center Console)

HOISTING > STANDARD PROCEDURE > STANDARD PROCEDURE - JACKING AND HOISTING LIFT POINTS

Fig 1: Jacking And Hoisting Lift Points

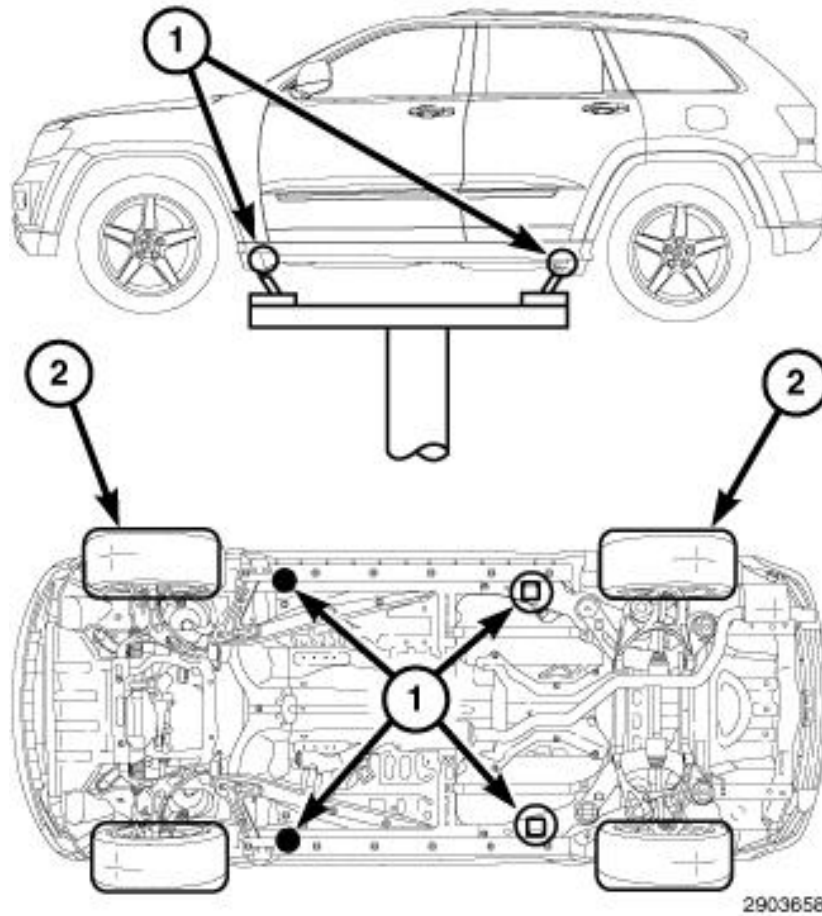

Courtesy of CHRYSLER GROUP, LLC

1 - FLOOR JACK, VEHICLE EMERGENCY JACK
1 - CHASSIS LIFT (DUAL POST)
1 - OUTBOARD LIFT (DUAL LIFT)
2 - DRIVE ON HOIST

Refer to Owner's Manual provided with vehicle for proper emergency jacking procedures.

⊗ WARNING:

The hoisting and jack lifting points provided are for a complete vehicle. When the engine or rear suspension is removed from a vehicle, the center of gravity is altered making some hoisting conditions unstable. Properly support or secure vehicle to hoisting device when these conditions exist. Failure to follow these instructions may result in personal injury or death.

⊗ WARNING:

Support the vehicle by supplemental means before performing any work on the air suspension system to prevent the vehicle from changing height. Before any given component is to be serviced it must be deflated. Servicing the air suspension system without supplemental support, or with pressure in the specific component, can cause possible serious or fatal injury.

📄 NOTE:

The air suspension system will auto-disable when lifted on a frame hoist, or when jacking one corner of the vehicle. The air suspension may attempt to change height slightly prior to switching to auto-disable. A manual disable is also available by pressing the "Up" and "Down" switches of the terrain select switch simultaneously for more than 5 seconds. The air suspension system will return to normal operation when the vehicle speed reaches 25 kph (15 mph).

When properly positioned, a floor jack can be used to lift the vehicle and support the raised vehicle with jack stands.

A floor jack or any lifting device, must never be used on any part of the underbody other than the described areas.

 **CAUTION:**

Do not attempt to lift a vehicle with a floor jack positioned under:

- *Aluminum differential.*
- *A body side sill.*
- *A steering linkage component.*
- *A drive shaft.*
- *The engine or transmission oil pan.*
- *The fuel tank.*

JUMP STARTING > STANDARD PROCEDURE > STANDARD PROCEDURE - JUMP STARTING

 **WARNING:**

Review all safety precautions and warnings in the Battery System Service Information. Refer to BATTERY SYSTEM - SERVICE INFORMATION .

- *Do not jump start a frozen battery, personal injury can result.*
- *If equipped, do not jump start when maintenance free battery indicator dot is yellow or bright color.*
- *Do not jump start a vehicle when the battery fluid is below the top of lead plates.*
- *Do not allow jumper cable clamps to touch each other when connected to a booster source.*
- *Do not use open flame near battery.*
- *Remove metallic jewelry worn on hands or wrists to avoid injury by accidental arcing of battery current.*
- *When using a high output boosting device, do not allow battery voltage to exceed 16 volts. Refer to instructions provided with device being used.*

Failure to follow these instructions may result in personal injury or death.

 **CAUTION:**

When using another vehicle as a booster, do not allow vehicles to touch. Electrical systems can be damaged on either vehicle.

JUMP STARTING > STANDARD PROCEDURE > STANDARD PROCEDURE - JUMP STARTING > TO JUMP START A DISABLED VEHICLE:

Fig 1: RED Jumper Cable Clamp & BLACK Jumper Cable Clamp

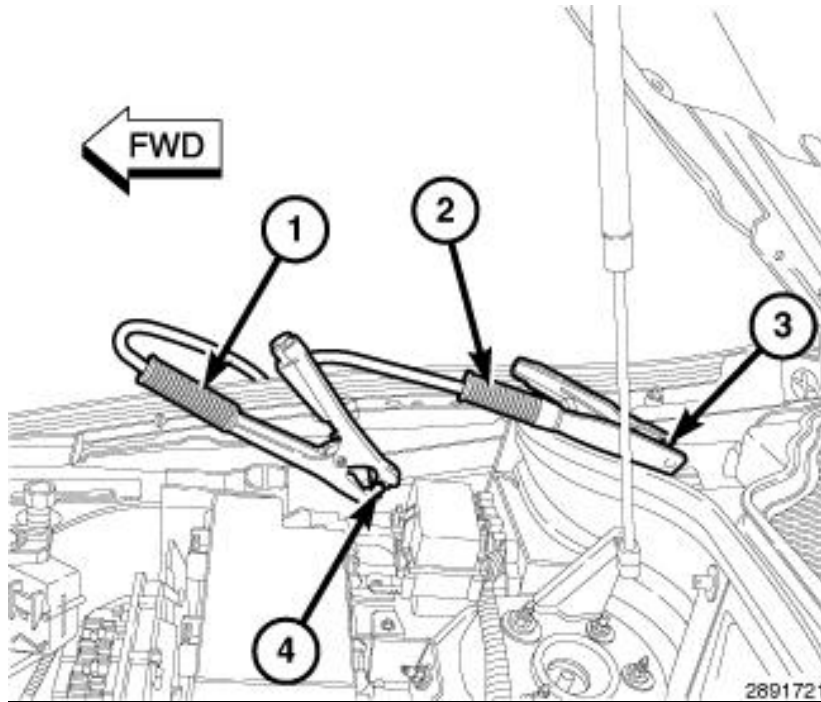

Courtesy of CHRYSLER GROUP, LLC

1. On the disabled vehicle, remove the battery compartment lid from under the passenger seat and inspect the battery.
 1. Inspect the battery cable terminal clamps for damage. Replace any battery cable that has a damaged or deformed terminal clamp.
 2. Inspect the battery tray and battery hold down hardware for damage. Replace any damaged parts.
 3. Slide the thermal guard off of the battery case, if equipped. Inspect the battery case for cracks or other damage that could result in electrolyte leaks. Also, check the battery terminal posts for looseness. Batteries with damaged cases or loose terminal posts must be replaced.
 4. Inspect the battery thermal guard for tears, cracks, deformation or other damage. Replace any battery thermal guard that has been damaged.
 5. Inspect the battery built-in test indicator sight glass (if equipped) for an indication of the battery condition. If the battery is discharged, charge as required. Refer to BATTERY, AGM, STANDARD PROCEDURE .
2. Raise hood on disabled vehicle and visually inspect engine compartment for:
 1. Generator drive belt condition and tension.

⚠ CAUTION:

If the cause of starting problem on disabled vehicle is severe, damage to booster vehicle charging system can result.

3. When using another vehicle as a booster source, park the booster vehicle within cable reach. Turn off all accessories, set the parking brake, place the automatic transmission in PARK or the manual transmission in NEUTRAL and turn the ignition OFF.
4. On disabled vehicle, place gear selector in park or neutral and set park brake. Turn off all accessories.
5. Connect jumper cables to booster battery. RED clamp to positive terminal (+). BLACK clamp to negative terminal (-). DO NOT allow clamps at opposite end of cables to touch, electrical arc will result. Review all warnings in this procedure.
6. On the disabled vehicle, pull up and remove the protective cover over the remote positive (+) battery post (3).
7. Connect the RED jumper cable clamp (2) to positive (+) terminal (3). Connect BLACK jumper cable clamp (1) to engine ground (1).
8. Start the engine in the vehicle which has the booster battery, let the engine idle a few minutes, then start the engine in the vehicle with the discharged battery.

 **CAUTION:**

Do not crank starter motor on disabled vehicle for more than 15 seconds, starter will overheat and could fail.

9. Allow battery in disabled vehicle to charge to at least 12.4 volts (75% charge) before attempting to start engine. If engine does not start within 15 seconds, stop cranking engine and allow starter to cool (15 min.), before cranking again.

JUMP STARTING > STANDARD PROCEDURE > STANDARD PROCEDURE - JUMP STARTING > DISCONNECT CABLE CLAMPS AS FOLLOWS:

- Disconnect BLACK cable clamp (1) from engine ground on disabled vehicle.
- When using a Booster vehicle, disconnect BLACK cable clamp from battery negative terminal. Disconnect RED cable clamp from battery positive terminal.
- Disconnect RED cable clamp (2) from battery positive terminal on disabled vehicle.

MAINTENANCE SCHEDULES > DESCRIPTION > MAINTENANCE SCHEDULES - NAFTA

Your vehicle is equipped with an automatic oil change indicator system. The oil change indicator system will remind you that it is time to take your vehicle in for scheduled maintenance. Based on engine operation conditions, the oil change indicator message will illuminate. This means that service is required for your vehicle. Operating conditions such as frequent short trips, trailer tow, extremely hot or cold ambient temperatures, and E85 fuel usage will influence when the "Oil Change Required" message is displayed. Severe Operating Conditions can cause the change oil message to illuminate as early as 3, 500 miles (5, 600 km) since last reset. Have your vehicle serviced as soon as possible, within the next 500 miles (805 km).

 **NOTE:**

Under no circumstances should oil change intervals exceed 10, 000 miles (16, 000 km), twelve months or 350 hours of engine run time, whichever comes first. The 350 hours of engine run or idle time is generally only a concern for fleet customers.

Oil Change Indicator - RESET

- Unless reset, this message continues to display each time you turn the ignition switch to the ON/RUN position. To turn off the message temporarily, press and release the Menu button. To reset the oil change indicator system (after performing the scheduled maintenance) perform the following procedure:
 - Turn the ignition switch to the "ON" position (Do not start the engine).
 - Fully depress the accelerator pedal slowly three times within 10 seconds.
 - Turn the ignition switch to the "LOCK" position.

 **NOTE:**

If the indicator message illuminates when you start the vehicle, the oil change indicator system did not reset. If necessary repeat this procedure.

Severe Duty All Models

Change Engine Oil at 4, 000 miles (6, 500 km) if the vehicle is operated in a dusty and off road environment or is operated predominately at idle or only very low engine RPM's. This type of vehicle use is considered Severe Duty.

Once a Month Or Before a Long Trip

- Check engine oil level
- Check windshield washer fluid level
- Check tire inflation pressures and look for unusual wear or damage.
- Check the fluid levels of the coolant reservoir, brake master cylinder and fill as needed.
- Check function of all interior and exterior lights.

At Every Oil Change Interval As Indicated By Oil Change Indicator System:

- Change the engine oil filter.
- Rotate the tires. **Rotate at the first sign of irregular wear, even if it occurs before the oil indicator system turns on.**

- Inspect battery and clean and tighten terminals as required.
- Inspect brake pads, shoes, rotors, drums, hoses and park brake.
- Inspect engine cooling system protection and hoses.
- Inspect exhaust system.
- Inspect engine air cleaner if using in dusty or off-road conditions.

MAINTENANCE CHART

Mileage or time passed (whichever comes first)	20,000	30,000	40,000	50,000	60,000	70,000	80,000	90,000	100,000	110,000	120,000	130,000	140,000	150,000
Or Years:	2	3	4	5	6	7	8	9	10	11	12	13	14	15
Or Kilometers:	32,000	48,000	64,000	80,000	96,000	112,000	128,000	144,000	160,000	176,000	192,000	208,000	224,000	240,000
Additional Inspections														
Inspect the CV joints.		X			X			X			X			X
Inspect front suspension, tie rod ends, and replace if necessary.	X		X		X		X		X		X		X	
Inspect the front and rear axle fluid, change if using your vehicle for police, taxi, fleet, off-road or frequent trailer towing.	X		X		X		X		X		X		X	
Inspect the brake linings, parking brake function.	X		X		X		X		X		X		X	
Inspect transfer case fluid.		X			X			X						X
Additional Maintenance														
Replace engine air filter.		X			X			X			X			X
Replace the air conditioning filter.	X		X		X		X		X		X		X	
Replace spark plugs.**									X					
Flush and replace the engine coolant at 10 years or 150,000 miles (240,000 km) whichever comes first.									X					X
Change transfer case fluid.											X			
Inspect and replace PCV valve if necessary.									X					

** The spark plug change interval is mileage based only, yearly intervals do not apply.

MAINTENANCE SCHEDULES > DESCRIPTION > MAINTENANCE SCHEDULES - NAFTA - SRT

The Scheduled Maintenance services listed in this Service Information must be done at the times or mileages specified to protect your vehicle warranty and ensure the best vehicle performance and reliability. More frequent

necessary.+

* The spark plug change interval is mileage based only, yearly intervals do not apply.

+ This maintenance is recommended by the manufacturer to the owner, but is not required to maintain emissions warranty.

Severe Duty Conditions

- ++ Change the engine oil and engine oil filter at every 4500 miles (7, 500 km) or 12 months if using your vehicle under any of the following severe duty conditions:
 - Stop and go driving.
 - Driving in dusty conditions.
 - Short trips of less than 10 miles (16 km).
 - Trailer towing.
 - Taxi, police, or delivery service (commercial service).
 - Off-road or desert operation.

MAINTENANCE SCHEDULES > DESCRIPTION > MAINTENANCE SCHEDULES - EUROPE - DIESEL

Your vehicle is equipped with an automatic oil change indicator system. The oil change indicator system will remind you that it is time to take your vehicle in for scheduled maintenance. Based on engine operation conditions, the oil change indicator message will illuminate. This means that service is required for your vehicle. Operating conditions such as frequent short-trips, trailer tow, extremely hot or cold ambient temperatures will influence when the "Oil Change Required" message is displayed.

NOTE:

Under no circumstances should oil change intervals exceed 12, 500 miles (20 000 km) or 12 months, whichever comes first.

NOTE:

Flush and replace the engine coolant at 120 months or 150, 000 miles (240, 000 km) whichever comes first.

Oil Change Indicator - RESET

- Unless reset, this message continues to display each time you turn the ignition switch to the ON/RUN position. To turn off the message temporarily, press and release the Menu button. To reset the oil change indicator system (after performing the scheduled maintenance) perform the following procedure:
 - Turn the ignition switch to the "ON" position (Do not start the engine).
 - Fully depress the accelerator pedal slowly three times within 10 seconds.
 - Turn the ignition switch to the "LOCK" position.

NOTE:

If the indicator message illuminates when you start the vehicle, the oil change indicator system did not reset. If necessary repeat this procedure.

At Each Stop for Fuel

- Check the engine oil level about 5 minutes after a fully warmed engine is shut off. Checking the oil level while the vehicle is on level ground will improve the accuracy of the oil level reading. Add oil only when the level is at or below the ADD or MIN mark.
- Check the windshield washer solvent and add if required.

Once a Month

- Check tire pressure and look for unusual wear or damage. Rotate tires at the first sign of irregular wear.
- Inspect the battery and clean and tighten the terminals as required.
- Check the fluid levels of the coolant reservoir, brake master cylinder, and power steering; add fluid as needed.
- Check all lights and other electrical items for correct operation.

At Each Oil Change

- Change the engine oil filter.
- Inspect the brake hoses and lines.

MAINTENANCE CHART

Miles or time passed (whichever comes first):	12,500	25,000	37,500	50,000	62,500	75,000	87,500	100,000	112,500	125,000	137,500	150,000
Or Months:	12	24	36	48	60	72	84	96	108	120	132	144
Kilometers:	20,000	40,000	60,000	80,000	100,000	120,000	140,000	160,000	180,000	200,000	220,000	240,000
Change engine oil and oil filter.	X	X	X	X	X	X	X	X	X	X	X	X
Completely fill the AdBlue tank.	X	X	X	X	X	X	X	X	X	X	X	X
Rotate tires	X	X	X	X	X	X	X	X	X	X	X	X
If using your vehicle for any of the following: Dusty or off-road conditions. Inspect the engine air cleaner filter, replace if necessary.	X	X	X	X	X	X	X	X	X	X	X	X
Inspect the brake linings, replace if necessary.	X	X	X	X	X	X	X	X	X	X	X	X
Inspect exhaust system.	X	X		X		X		X		X		X
Inspect CV Joints		X		X		X		X		X		X
Inspect the front suspension, tie rod ends and boot seals, replace if necessary.		X		X		X		X		X		X
Change brake fluid every 24 months if using DOT 4 brake fluid.		X		X		X		X		X		X
Inspect the front and rear axle fluid, change if using your vehicle for police, taxi, fleet, off road or frequent trailer towing.		X		X		X		X		X		X
Replace the fuel filter.		X		X		X		X		X		X
Adjust parking brake on vehicles equipped with four-wheel disc brakes.		X		X		X		X		X		X
Replace engine air cleaner filter.		X		X		X		X		X		X
Replace air conditioning/cabin air filter	X	X	X	X	X	X	X	X	X	X	X	X
Replace accessory drive belt(s).								X				
Flush and replace the engine coolant at 10 years or 150,000 miles (240,000 km) whichever comes first.										X		X
Inspect or change the transfer case fluid if using your vehicle for any of the following: police, taxi, fleet, or frequent trailer towing.		X				X				X		
Change the transfer case fluid				X				X				X

MAINTENANCE SCHEDULES > DESCRIPTION > MAINTENANCE SCHEDULES - PUERTO RICO

Your vehicle is equipped with an automatic oil change indicator system. The oil change indicator system will remind you that it is time to take your vehicle in for scheduled maintenance. Based on engine operation conditions, the oil change indicator message will illuminate. This means that service is required for your vehicle. Operating conditions such as frequent short trips, trailer tow, extremely hot or cold ambient temperatures, and E85 fuel usage will influence when the "Oil Change Required" message is displayed. Severe Operating Conditions can cause the change oil message to illuminate as early as 3,500 miles (5,600 km) since last reset. Have your vehicle serviced as soon as possible, within the next 500 miles (805 km).

 **NOTE:**

Under no circumstances should oil change intervals exceed 10,000 miles (16,000 km), twelve months or 350 hours of engine run time, whichever comes first. The 350 hours of engine run or idle time is generally only a concern for fleet customers.

Oil Change Indicator - RESET

- Unless reset, this message continues to display each time you turn the ignition switch to the ON/RUN position. To turn off the message temporarily, press and release the Menu button. To reset the oil change indicator system (after performing the scheduled maintenance) perform the following procedure:
 - Turn the ignition switch to the "ON" position (Do not start the engine).
 - Fully depress the accelerator pedal slowly three times within 10 seconds.
 - Turn the ignition switch to the "LOCK" position.

 **NOTE:**

If the indicator message illuminates when you start the vehicle, the oil change indicator system did not reset. If necessary repeat this procedure.

Severe Duty All Models

Change Engine Oil at 4,000 miles (6,500 km) if the vehicle is operated in a dusty and off road environment or is operated predominately at idle or only very low engine RPM's. This type of vehicle use is considered Severe Duty.

Once a Month Or Before a Long Trip

- Check engine oil level
- Check windshield washer fluid level
- Check tire inflation pressures and look for unusual wear or damage.
- Check the fluid levels of the coolant reservoir, brake master cylinder and fill as needed.
- Check function of all interior and exterior lights.

At Every Oil Change Interval As Indicated By Oil Change Indicator System:

- Change the engine oil filter.
- Rotate the tires. **Rotate at the first sign of irregular wear, even if it occurs before the oil indicator system turns on.**
- Inspect battery and clean and tighten terminals as required.
- Inspect brake pads, shoes, rotors, drums, hoses and park brake.
- Inspect engine cooling system protection and hoses.
- Inspect exhaust system.
- Inspect engine air cleaner if using in dusty or off-road conditions.

MAINTENANCE CHART

Mileage or time passed (whichever comes first)	20,000	30,000	40,000	50,000	60,000	70,000	80,000	90,000	100,000	110,000	120,000	130,000	140,000	150,000
Or Years:	2	3	4	5	6	7	8	9	10	11	12	13	14	15
Or Kilometers:	32,000	48,000	64,000	80,000	96,000	112,000	128,000	144,000	160,000	176,000	192,000	208,000	224,000	240,000
Additional Inspections														

Inspect the CV joints.		X			X			X			X			X
Inspect front suspension, tie rod ends, and replace if necessary.	X		X		X		X		X		X		X	
Inspect the front and rear axle fluid, change if using your vehicle for police, taxi, fleet, off-road or frequent trailer towing.	X		X		X		X		X		X		X	
Inspect the brake linings, parking brake function.	X		X		X		X		X		X		X	
Inspect transfer case fluid.		X			X			X						X
Additional Maintenance														
Replace engine air filter.		X			X			X			X			X
Replace the air conditioning filter.	X		X		X		X		X		X		X	
Replace spark plugs.**									X					
Flush and replace the engine coolant at 10 years or 150,000 miles (240,000 km) whichever comes first.											X			X
Change transfer case fluid.											X			
Inspect and replace PCV valve if necessary.									X					

** The spark plug change interval is mileage based only, yearly intervals do not apply.

MAINTENANCE SCHEDULES > DESCRIPTION > MAINTENANCE SCHEDULES - NAFTA - DIESEL FUEL UP TO B5 BIODIESEL

Your vehicle is equipped with an automatic oil change indicator system. The oil change indicator system will remind you that it is time to take your vehicle in for scheduled maintenance. Based on engine operation conditions, the oil change indicator message will illuminate. This means that service is required for your vehicle. Operating conditions such as frequent short trips, trailer tow, extremely hot or cold ambient temperatures will influence when the "Oil Change Required" message is displayed. Severe Operating Conditions can cause the change oil message to illuminate as early as 3,500 miles (5,600 km) since last reset. Have your vehicle serviced as soon as possible, within the next 500 miles (805 km).



NOTE:

Under no circumstances should oil change intervals exceed 10,000 miles (16,000 km) or twelve months, whichever comes first.

Oil Change Indicator - RESET

- Unless reset, this message continues to display each time you turn the ignition switch to the ON/RUN position. To turn off the message temporarily, press and release the Menu button. To reset the oil change indicator system (after performing the scheduled maintenance) perform the following procedure:
 - Turn the ignition switch to the "ON" position (Do not start the engine).
 - Fully depress the accelerator pedal slowly three times within 10 seconds.

Inspect the brake linings, parking brake function.		X		X		X		X		X		X		X
Inspect transfer case fluid.			X		X			X						X
Additional Maintenance														
Drain water from fuel filter assembly.	X	X		X	X			X	X			X	X	
Replace fuel filters and drain water from the fuel filter assembly.			X		X			X			X			X
Replace engine air filter.			X		X			X			X			X
Replace the air conditioning filter.		X		X	X			X			X			X
Flush and replace the engine coolant at 10 years or 150,000 miles (240,000 km) whichever comes first.										X				X
Replace accessory drive belt(s).										X				
Change transfer case fluid.											X			

MAINTENANCE SCHEDULES > DESCRIPTION > MAINTENANCE SCHEDULES - NAFTA - B6 TO B20 BIODIESEL

Your vehicle is equipped with an automatic oil change indicator system. The oil change indicator system will remind you that it is time to take your vehicle in for scheduled maintenance. Based on engine operation conditions, the oil change indicator message will illuminate. This means that service is required for your vehicle. Operating conditions such as frequent short trips, trailer tow, extremely hot or cold ambient temperatures will influence when the "Oil Change Required" message is displayed. Severe Operating Conditions can cause the change oil message to illuminate as early as 3,500 miles (5,600 km) since last reset. Have your vehicle serviced as soon as possible, within the next 500 miles (805 km).

NOTE:

Under no circumstances should oil change intervals exceed 10,000 miles (16,000 km) or twelve months, whichever comes first.

Oil Change Indicator - RESET

- Unless reset, this message continues to display each time you turn the ignition switch to the ON/RUN position. To turn off the message temporarily, press and release the Menu button. To reset the oil change indicator system (after performing the scheduled maintenance) perform the following procedure:
 - Turn the ignition switch to the "ON" position (Do not start the engine).
 - Fully depress the accelerator pedal slowly three times within 10 seconds.
 - Turn the ignition switch to the "LOCK" position.

NOTE:

If the indicator message illuminates when you start the vehicle, the oil change indicator system did not reset. If necessary repeat this procedure.

Engine Oil Filter Replacement

- Residual oil in the housing may spill from the housing when the new filter is installed if the residual oil is not either removed from the housing or enough time has not elapsed to allow the oil to drain back into the engine.

When servicing the oil filter on this engine, carefully remove the filter and use a suction gun to remove any residual oil left in the housing or wait about 30 minutes for the oil to drain back into the engine.

Once a Month Or Before a Long Trip

- Check engine oil level
- Check windshield washer fluid level
- Check tire inflation pressures and look for unusual wear or damage.
- Check the fluid levels of the coolant reservoir, brake master cylinder, and power steering and fill as needed
- Check function of all interior and exterior lights.

At Every Oil Change Interval As Indicated By Oil Change Indicator System:

- Change oil and filter.
- Completely fill the Diesel Exhaust Fluid tank.
- Drain water from fuel filter assembly.
- Rotate the tires. **Rotate at the first sign of irregular wear, even if it occurs before the oil indicator system turns on.**
- Inspect battery and clean and tighten terminals as required.
- Inspect brake pads, shoes, rotors, drums, hoses and park brake.
- Inspect engine cooling system protection and hoses.
- Inspect exhaust system.
- Inspect engine air cleaner if using in dusty or off-road conditions.

MAINTENANCE CHART - DIESEL FUEL B6 TO B20 BIODIESEL

Mileage or time passed (whichever comes first)	10,000	20,000	30,000	40,000	50,000	60,000	70,000	80,000	90,000	100,000	110,000	120,000	130,000	140,000	150,000
Or Years:	1	2	3	4	5	6	7	8	9	10	11	12	13	14	15
Or Kilometers:	16,000	32,000	48,000	64,000	80,000	96,000	112,000	128,000	144,000	160,000	176,000	192,000	208,000	224,000	240,000
Additional Inspections															
Completely fill the Diesel Exhaust Fluid tank.	X	X	X	X	X	X	X	X	X	X	X	X	X	X	X
Inspect the CV joints.			X			X			X			X			X
Inspect front suspension, tie rod ends, and replace if necessary.		X		X		X		X		X		X		X	
Inspect the front and rear axle fluid, change if using your vehicle for police, taxi, fleet, off-road or frequent trailer towing.		X		X		X		X		X		X		X	
Inspect the brake linings, parking brake function.		X		X		X		X		X		X		X	
Inspect transfer case fluid.			X			X			X						X
Additional B6 to B20 Maintenance															
Drain water from fuel filter assembly.	X	X		X	X		X	X		X	X		X	X	

Replace fuel filters and drain water from the fuel filter assembly.		X		X		X		X		X		X		X
Replace engine air filter.			X		X			X		X				X
Replace the air conditioning filter.		X		X		X		X		X		X		X
Flush and replace the engine coolant at 10 years or 150,000 miles (240,000 km) whichever comes first.										X				X
Replace accessory drive belt(s).										X				
Change transfer case fluid.												X		

NEW VEHICLE PREPARATION INSTRUCTIONS > STANDARD PROCEDURE > STANDARD PROCEDURE - NEW VEHICLE PREPARATION

VEHICLE READINESS	
<div style="border: 1px solid black; padding: 5px;"> <p> NOTE:</p> <p><i>Note: This document is for reference purposes only. The instructions are not VIN-specific, and it is not required to print or retain this document for each New Vehicle Prep performed.</i></p> </div>	
Description	Action
Keep All Protective Transit Film and Wheel Covers & Films on vehicle until sold, or up to 180 Days	Keep All Protective Transit Film and Wheel Covers & Films on vehicle until sold, or up to 180 Days.
Place vehicle into Customer Mode	<ol style="list-style-type: none"> 1. Turn the ignition key on (No engine cranking or running required) 2. Turn on the hazard lamp (a/k/a/ emergency flashers) 3. Press the "Up Arrow" button on the steering wheel and hold for 5 seconds. 4. Mode is switched from "Shipping Mode" to "Customer Mode" - the EVIC display will update. 5. Turn off the hazard lamps
Inflate tire pressure to max sidewall pressure (except Viper)	Increase the tire pressure to maximum sidewall pressure if vehicle is going into lot storage.
Verify vehicle is built as invoiced	Verify vehicle is built as invoiced
Install all "Shipped Loose" items (except Viper)	Install all "Shipped Loose" items.
Install Front License Plate Bracket (if required)	Install Front License Plate Bracket.
Install Antenna	Install Antenna.
Perform all Incomplete Recalls and RRTs	Perform all Incomplete Recalls and RRTs
Install Wheel Center Caps	Install Wheel Center Caps.
UNDERHOOD	
Description	Action
Hood Latch and Safety Catch - Adjust as Needed	Verify the operation of the hood release system including the inside hood release lever and the outside hood secondary safety catch. Adjust if necessary. The safety

	catch prevents the hood from going to the full open position until it is manually released. To test the safety catch, unlatch the hood with the interior hood release lever and attempt to raise the hood without operating the safety catch.
Battery State-of-Charge - document voltage	Check the battery state of charge by connecting a digital voltmeter at the jump-start locations. The battery voltage should be at least 12.4 volts (Fiat 500 BEV -100%). If charging is necessary, follow the service information procedures and recharge the battery. Record voltage on New Vehicle Prep (NVP) form.
Loose Attachments, Routing and Clearance	Inspect the following for routing, loose attachments, connections, and clearance. Reroute and tighten as required: Brake Lines, Fuel Lines, Power Steering Hoses, Vacuum Hoses, Clutch Lines, Refrigerant Lines, Wiring, Belts.
All Fluid Levels	Refer to the owner's manual or service information for proper fluid level inspection locations. Vehicles equipped with the eight-speed automatic transmission do not require the fluid to be checked. In addition, it is also not necessary to check the fluid of the manual transmission on Vipers and Challengers.
Top-Off Diesel Exhaust Fluid Reservoir (diesel equipped)	"Fill the DEF reservoir with DEF (diesel equipped). NOTE: TOP OFF THE DEF RESERVOIR PRIOR TO ANY ECU FLASH THAT MAY NEED TO BE PERFORMED. NOTE: DEF IS REIMBURSABLE DURING NEW VEHICLE PREPERATION"
No Fluid Leaks present	Visually inspect the underhood area to ensure absence of fluid leaks. Check clamps for tightness and full engagement.

UNDER VEHICLE	
Description	Action
No Fluid Leaks present	Raise the vehicle on an appropriate hoist and check the following: Loose Attachments, Routing Clearance and Damage, Absence of Fluid Leaks. Refer to HOISTING for proper lift points. Check clamps for tightness and full engagement.
All Fluid Levels	Refer to the owner's manual or service information for proper fluid level inspection locations. Vehicles equipped with the eight-speed automatic transmission do not require the fluid to be checked. In addition, it is also not necessary to check the fluid of the manual transmission on Vipers and Challengers models. Also, do not top off the axle fluid on Ram 1500, Challenger, Charger, 300, Durango, and Grand Cherokee models.
Loose Attachments, Routing, Clearance, Damage	Raise the vehicle on an appropriate hoist and check the following: Loose Attachments, Routing Clearance and Damage, Absence of Fluid Leaks. Refer to HOISTING for proper lift points. Check clamps for tightness and full engagement.

ROAD TEST/OPERATIONAL TEST	
Description	Action
Perform Road Test, Mileage: Before _____ After _____ NOTE: NOT REQUIRED ON VIPER.	Perform road test (8-10mile, 10-15km guideline) on a variety of road surfaces. Record mileage before and after road test.
Engine Starts with All Keys	Start vehicle with all sets of keys.
All Warning Lights and Gauges / No DTCs	Verify all warning lights and gauges are operating properly, and no fault codes exist.
Keyless Go	Ensure vehicle starts with push button, when key is inside vehicle.
Engine Starts Only in Park & Neutral	Verify engine will only start while automatic transmission is in park or neutral.
Service and Parking Brakes	Apply the service brakes while the car is in motion. Be sure the brake operation is smooth and positive. Make sure the vehicle stops in a straight line and without pulling to one side. Ensure there is no shudder or vibration when braking. Ensure that the parking brake is easy to operate. Make sure the parking brake does not drag.

Brake Transmission Shift Interlock	Ensure that the vehicle will only start when the brake is depressed on vehicles with automatic transmission.
Automatic Transmission Shifting	Make sure that the park lock mechanism holds the vehicle. With the vehicle on a grade, put the automatic transmission in park and slowly release the service brake to check the operation of the park mechanism. Make sure the shift lever operates easily and smoothly. Check for smooth shifting. Check for proper upshifting and downshifting.
Engine Performance - Cold	The engine should: start properly, idle smoothly and at proper speed, be free from stumbling or hesitation, produce sufficient power, be free of unusual noises, operate within the proper temperature range, and stop when the ignition key is shut off or stop button is depressed.
Steering and Handling	Check that the power assist works properly. Make sure that the steering wheel does not vibrate abnormally at idle or road speed. Ensure that the steering wheel is centered when traveling in a straight line. Check that the vehicle does not drift to either side on flat road surfaces. Make sure that the vehicle does not vibrate or shake abnormally.
Noise, Vibration, Squeaks, or Rattles	Check that the vehicle is free of noise, vibrations, squeaks, or rattles. Tighten any loose fasteners.
Heater / Defrost- Front	Check the heater operation after the vehicle has reached operating temperature. Operate blower motor at all speeds. Operate the system in all modes. Check for hot air at all appropriate outlets. Check for temperature control operation.
Air Conditioning	Ensure that the A/C system cools properly. Operate blower motor at all speeds. Check for cool air at all temperature outlets. Operate the system in all modes.
Defrost - Rear	Ensure that the electric heated rear defroster operates correctly. Turn on and feel for warmth.
Blindspot Monitoring System (if equipped)	While on road test, verify that the visual warning indicators located on the side view mirrors are operating properly when an object is within the detection zone.
Cruise Control (if equipped)	Check the "on/off" switch. Check the "set" operation. Check the "resume" function. Check the "accelerate" and "decelerate" function. Check the "cancel" button. Check the brake/clutch release function. If equipped, verify operation of Adaptive Cruise Control function.
Set Compass Variance / Calculation (if equipped)	Refer to the service information on TechCONNECT for information regarding compass setting procedures.
Transfer Case (if equipped)	Shift the transfer case through all ranges to make sure all shifting is smooth and operates properly.
Load Leveling Air Suspension (if equipped)	Use the terrain select switch to change the ride height during normal driving conditions. Cycle through each selection and verify proper operation of the air suspension system.
Tire Pressure Monitoring System	Verify that Tire Pressure Monitoring Indicator Light is not illuminated when tires are above minimum inflation recommendations. Ensure that indicator lamp is not flashing/chiming.
Engine Performance - Warm	The engine should: start properly, idle smoothly and at proper speed, be free from stumbling or hesitation, produce sufficient power, be free of unusual noises, operate within the proper temperature range, and stop when the ignition key is shut off or stop button is depressed.
Park Assist (if equipped)	Put vehicle in reverse and slowly back up toward an object. Verify that Park Assist warning icon, lights and chimes operate properly as object is approached.
Back-Up Camera (if equipped)	Put vehicle in reverse, verify that screen provides a clear and visible image from rear of vehicle.

INTERIOR	
Description	Action
Visually Inspect Interior Parts for Damage, Fit, etc.	From the interior of the vehicle, open and close all doors to ensure ease of operation. Fully open and close the

	glove box to ensure proper operation. Fully open and close the console door to ensure proper operation. Check interior panels for proper fit and free from damage.
All Interior Lamps and Horn	Operate and visually inspect all interior lights and switches, including: Dome/Map lamps, and if equipped the following: vanity mirror lamps, glove box lamps, ash tray lamp, cigar lighter lamp, radio lamps, door mounted lamps, illuminated entry system. Ensure that the horn operates properly.
Rear View Mirror	Check that the rearview mirror's day/night function is operating properly.
Front and Rear Wipers and Washers	Activate front windshield wipers, and if equipped, rear window wipers and check for proper operation at all speeds. Activate the front and if equipped, the rear washer. Check the spray pattern for proper operation and aim. Check the intermittent wipe feature for proper operation.
All interior Door Locks including Child Locks	Check all interior door locks for proper operation, including rear child safety door locks if equipped. Place in the unlocked position.
Steering Wheel Mounted Controls	Check all steering wheel controls for proper operation.
Memory Mirror / Seat	Verify the proper operation of the memory mirror, radio (if equipped), adjustable pedals (if equipped), and seat system.
Cigar Lighter	Check cigar lighter for proper operation.
Power Windows and Window Lock Switch	Fully open and close all power windows to ensure proper operation and sealing. Ensure that the windows operate properly at each door. Verify that window lock button is operating properly. Verify the operation of the "One Touch Up/Down" feature if equipped.
Outside Power Mirrors	Check power mirrors for proper operation.
Power Folding Outside Mirrors	Press Power Folding Mirror button on driver side door trim panel. The switch is located between the Left and Right Power Mirror buttons.
Power Heated Mirrors (if equipped)	Check power heated mirrors for proper operation.
Seats and Seat Belts - All Adjustments	Check for correct installation and operation of seat and shoulder belts, and retractors. Check that the restraint system safety labels regarding the use of seatbelts and airbags are in place. Fully cycle the seats for proper adjustments and verify that each seat is securely mounted. Fold down and latch the rear seats. Pull forward to check that the latches operate correctly. Check for proper head restraint operation. NOTE: ON GRAND CHEROKEE MODELS, MAKE SURE THE SECOND ROW SEATS ARE UNBUCKLED.
Power Sunroof (if equipped)	Cycle sunroof. Ensure that the sunroof opens and closes easily. Verify proper operation of one touch open/close feature if equipped.
Set Clock(s)	Set all clocks to correct time. Refer to Owner's Manual for information regarding clock setting procedures.
Audio System	Turn the radio on and check reception in both AM and FM modes. Check that the CD player operates properly. Check for good sound quality from all speakers.
Satellite Radio (if equipped)	Turn on satellite radio and verify reception.
Confirm UCONNECT Language Set To Market	Refer to User Guide to perform any radio updates/settings.
Confirm EVIC Set To Market Unit and Language	Refer to User Guide to perform any radio updates/settings.
GPS Navigation	Verify GPS Functions.
Cycle Glovebox Lock	Using the key, ensure the Glovebox Lock operates properly.
Video System (if equipped)	Test the DVD player to ensure that a DVD will load properly and display on the screen.
Heated Steering Wheel (if equipped)	Verify that heated steering wheel is functioning properly.
Power Outlet(s)	Check all power outlets for proper operation.
Integrated Child Seat / Belt	Check the child restraints and child seats for proper operation.

Storage bins properly seated around the spare tire (Grand Cherokee only)	Verify that storage bins are properly seated.
Heated Seats (if equipped)	Check for proper operation of heated seats on all power levels, on all equipped seats.
Power Cooled Seats (if equipped)	Check for proper operation of ventilated seats on all power levels, on all equipped seats.
Cargo Compartment Cover (if equipped)	Check the rear cargo compartment cover is operating properly.
Fuel Door Release	Activate the remote fuel door release to verify the fuel door will open.
Tilt/Telescoping Steering Column	Activate the manual/power tilt mechanism. Activate the telescoping feature of the steering column.

EXTERIOR	
Description	Action
Inspect Body and Paint for Damage and Fit/ Finish	Inspect the body exterior for damage, loose or missing items. During the inspection, ensure that no vehicle damage occurred from the time the vehicle was received and the beginning of the New Vehicle Preparation. Note: DO NOT TOUCH UP MATTE PAINT OR CUSTOM COLORS.
Remove door edge protector for all doors (if equipped)	Pull the door edge protector off from each door (if equipped)
Exterior Lamps - Headlamps, Turn Signals, Hazards, Park/Tail/License Plate, Trunk Lights, etc.	Operate and visually inspect the following: Headlamps (High/Low Beams), turn signals, hazard warning flashers, parking/tail/license plate lamps, reverse/back up lamps, fog lamps, stop lamps including center mounted stop lamp, daytime running lamps (if equipped), clearance lamps, cargo bed lamps, any other lamps.
Lock and Unlock all doors with all mechanical keys	Verify all doors lock and unlock with all mechanical keys including the liftgate, tailgate, or trunk as equipped. In addition, verify that both Ram Boxes lock and unlock with all mechanical keys (if equipped).
Doors, Liftgate and Tailgate- Adjust Strikers as Needed	Open each door/liftgate/tailgate from the outside to check outside door handle operation. Check the door detent. Partially close all doors to check the open-door detent. Close all doors/liftgates/tailgates to check the operation of latches and strikers. Adjust strikers as required. Verify liftgate/tailgate ease of operation.
Power Liftgate - Inspect for fit and operation (if equipped)	Verify all modes of operation of the power liftgate, including operating the liftgate using the inside switches and the Remote Keyless Entry transmitter.
Security Alarm Test (if equipped)	Lock doors using the Remote Keyless Entry Transmitter. Verify the operation of the Vehicle Security System warning lamp.
Remote Keyless Entry (if equipped)	Verify that doors unlock properly using all key FOBS.
Passive Entry/Keyless Go/Remote Proximity (if equipped)	Verify that the Keyless Enter-N-Go feature is operating properly, by grabbing the door handle of the locked vehicle, while the Remote Keyless Entry transmitter key is within 5 feet of the vehicle. The door should unlock automatically.
Remote Start (if equipped)	Verify that engine starts with all keys when using Remote Keyless Entry Transmitter.

VEHICLE STORAGE	
Description	Action
Keep all protective transit film, wheel covers and films on Vehicle Until Sold or Up To 180 Days	Keep all protective transit film, wheel covers and films on Vehicle Until Sold or Up To 180 Days
Inflate tire pressure to max side wall pressure	Inflate tire pressure to max side wall pressure (except heavy duty trucks.) Periodically move vehicles to prevent Flat Spotting on tires
Periodically move vehicles to prevent Flat Spotting on tires	Periodically move vehicles to prevent Flat Spotting on tires
Place vehicle into Ship Mode	<ol style="list-style-type: none"> 1. Turn the ignition key on (No engine cranking or running required) 2. Turn on the hazard lamp (a/k/a/ emergency)

	<p>flashers)</p> <ol style="list-style-type: none"> 3. Press the "Up Arrow" button on the steering wheel and hold for 5 seconds. 4. Mode is switched from "Customer Mode" to "Shipping Mode" - the EVIC display will update. 5. Turn off the hazard lamps.
--	---

FINAL DETAIL & INSPECTION	
Description	Action
Inspect paint and body, touch up as needed	Make sure that the body is free from paint chips or scratches. Touch up any chips/scratches using thin layers of paint. Ensure that the body is free from dings and dents. NOTE: ON VIPERS, DO NOT TOUCH UP MATTE PAINT OR CUSTOM COLORS.
Perform all incomplete recalls and RRT's (Print a current VIP Report)	Perform all incomplete recalls and RRT's (Print a current VIP Report).
Place vehicle into Customer Mode	<ol style="list-style-type: none"> 1. Turn the ignition key on (No engine cranking or running required) 2. Turn on the hazard lamp (a/k/a/ emergency flashers) 3. Press the "Up Arrow" button on the steering wheel and hold for 5 seconds. 4. Mode is switched from "Shipping Mode" to "Customer Mode" - the EVIC display will update. 5. Turn off the hazard lamps
Test and record battery state of charge	Check the battery state of charge by connecting a digital voltmeter at the jump-start locations. The battery voltage should be at least 12.4 volts (Fiat 500 BEV -100%). If charging is necessary, follow the service information procedures and recharge the battery. Record voltage on New Vehicle Prep (NVP) form.
Adjust tire pressures including spare to door placard	Adjust tire pressures including spare to door placard.
Ensure Center Caps are Installed	Ensure Center Caps are Installed
Top off Diesel Exhaust Fluid Reservoir (DEF Fluid IS reimbursable)	"Fill the Diesel Exhaust Fluid Reservoir located behind the cab on the driver's side of truck or behind the fuel filler door (DEF cap is clearly marked in blue) with Mopar Diesel Exhaust Fluid prior to customer delivery. NOTE: TOP OFF DEF PRIOR TO PERFORMING ANY REQUIRED PCM FLASH."
Remove interior and exterior Transportation Protective Covers	Remove exterior protective coatings/coverings from vehicle, remove interior protective covers, grease markings on door jambs, unnecessary labels, etc.
Wash and clean vehicle exterior	Wash the entire vehicle. Clean the tire sidewalls and wheel/wheel covers (use non - acidic wheel cleaner). Clean exterior/interior glass surfaces.
Clean vehicle interior	Inspect the interior trim, seats, carpeting, and moldings. Clean as necessary.

TOWING > STANDARD PROCEDURE > STANDARD PROCEDURE - TOWING

 **CAUTION:**

DO NOT use sling-type equipment when towing. When securing the vehicle to a flatbed truck, do not attach to front or rear suspension components. Damage to your vehicle may result from improper towing.

 **CAUTION:**

Towing this vehicle in violation of the below requirements can cause severe transmission damage. Damage from improper towing is not covered under the New Vehicle Limited Warranty.

 **NOTE:**

This Service Information describes procedures for towing a disabled vehicle using a commercial wrecker service.

 **NOTE:**

Vehicles equipped with Quadra-Lift must be placed in Transport mode, before tying them down (from the body) on a trailer or flatbed truck. Refer to the Owner's Manual section on Quadra-Lift for more information. If the vehicle cannot be placed in Transport mode (for example, engine will not run), tie-downs must be fastened to the axles (not to the body). Failure to follow these instructions may cause fault codes to be set and/or cause loss of proper tie-down tension.

Towing Condition	Wheels OFF the Ground	Two-Wheel Drive Models	Four-Wheel Drive Models Without 4-LO Range	Four-Wheel Drive Models With 4-LO Range
Flat Tow	NONE	NOT ALLOWED	NOT ALLOWED	See Instructions <ul style="list-style-type: none">• Transmission in PARK• Transfer case in NEUTRAL (N)• Tow in forward direction
Dolly Tow	Front	NOT ALLOWED	NOT ALLOWED	NOT ALLOWED
	Rear	OK	NOT ALLOWED	NOT ALLOWED
On Trailer	ALL	OK	OK	OK

Towing A Disabled Vehicle

- Proper towing or lifting equipment is required to prevent damage to your vehicle. Use only tow bars and other equipment designed for this purpose, following equipment manufacturer's instructions. Use of safety chains is mandatory. Attach a tow bar or other towing device to main structural members of the vehicle, not to bumpers or associated brackets. State and local laws regarding vehicles under tow must be observed.
- If you must use the accessories (wipers, defrosters, etc.) while being towed, the ignition must be in the ON/RUN position, not the ACC position.

Two-Wheel Drive Models

- The manufacturer recommends towing your vehicle with all four wheels **OFF** the ground using a flatbed.
- If flatbed equipment is not available, and the transmission is operable, the vehicle may be towed (with rear wheels on the ground) under the following conditions:
 - The transmission must be in NEUTRAL. Refer to "Manual Park Release" in the appropriate Service Information for instructions on shifting the transmission to NEUTRAL when the engine is off.
 - The towing speed must not exceed 30 mph (48 km/h).
 - The towing distance must not exceed 30 miles (48 km).

If the transmission is not operable, or the vehicle must be towed faster than 30 mph (48 km/h) or farther than 30 miles (48 km), tow with the rear wheels **OFF** the ground. Acceptable methods are to tow the vehicle on a flatbed, or with the front wheels raised and the rear wheels on a towing dolly, or (when using a suitable steering wheel stabilizer to hold the front wheels in the straight position) with the rear wheels raised and the front wheels on the ground.

Four-Wheel Drive Models

- The manufacturer recommends towing with all wheels **OFF** the ground. Acceptable methods are to tow the vehicle on a flatbed or with one end of vehicle raised and the opposite end on a towing dolly.

If flatbed equipment is not available, and the transfer case is operable, vehicles **with a two-speed transfer case** may be towed (in the forward direction, with **ALL** wheels on the ground), **IF** the transfer case is in NEUTRAL (N) and the transmission is in **PARK**. Refer to "Recreational Towing" in "Starting And Operating" for detailed instructions.

Vehicles equipped with a single-speed transfer case have no NEUTRAL position, and therefore **must** be towed with all four wheels **OFF** the ground.

DIAGNOSIS AND TESTING > DIAGNOSIS AND TESTING - AUDIO

Any diagnosis of the audio system should begin with the use of a diagnostic scan tool. Check for any Diagnostic Trouble Code (DTC) data. If a DTC is found, refer to the DTC INDEX article and perform the appropriate diagnostic procedure before proceeding. Refer to the appropriate wiring information.

 **WARNING:**

To avoid serious or fatal injury on vehicles equipped with airbags, disable the Supplemental Restraint System (SRS) before attempting any steering wheel, steering column, airbags, airbag curtains, knee blocker, seat belt tensioner, impact sensor or instrument panel component diagnosis or service. Refer to WARNING . Disconnect the IBS/negative battery cable assembly from the negative battery post, then wait two minutes for the system capacitor to discharge before performing further diagnosis or service. This is the only sure way to disable the SRS. Failure to take the proper precautions could result in accidental airbag deployment.

AUDIO SYSTEM DIAGNOSTIC TABLE

CONDITION	POSSIBLE CAUSES	CORRECTION
RADIO INOPERATIVE	1. Fuse inoperative.	Check radio fuse.
	2. Open wiring.	Check "No Response from Radio". Refer to NO RESPONSE FROM RADIO .
NO AUDIO - BUT RADIO LIGHTS UP	1. Antenna problem.	Perform the "Poor or No AM/FM Audio Reception" test. Refer to POOR OR NO AM/FM AUDIO RECEPTION .
	2. Radio or Amplifier (if equipped) connector damaged.	Check for loose or corroded radio/amplifier connector. Repair, as required.
	3. Wiring damaged.	Check for shorted or open wires. Repair wiring as required.
	4. Radio or Amplifier (if equipped) ground damaged.	Check for continuity between radio chassis and a known good ground. There should be continuity. Repair ground as required.
	5. Amplifier (if equipped) inoperative.	Refer to the DTC INDEX article. .
	6. Speakers inoperative.	Refer to DIAGNOSIS AND TESTING .
NO RADIO DISPLAY	1. Fuse inoperative.	Check radio fuse, Replace fuses as required.

	2. Radio connector damaged.	Check for loose or corroded radio connector. Repair as required.
	3. Wiring damaged.	Check for battery voltage at radio connector. Repair wiring as required.
	4. Radio ground circuit damaged.	Check for continuity between radio chassis and a known good ground. There should be continuity. Repair ground as required.
	5. Radio inoperative.	Check "No Response from Radio". Refer to NO RESPONSE FROM RADIO .
	6. Center stack screen	Refer to DIAGNOSIS AND TESTING .
POOR AM/FM RADIO RECEPTION	1. Antenna inoperative.	Perform the "Poor or No AM/FM Audio Reception" test. Refer to POOR OR NO AM/FM AUDIO RECEPTION .
	2. Radio ground damaged.	Check for continuity between radio chassis and a known good ground. There should be continuity. Repair ground as required.
	3. Radio inoperative.	Refer to DIAGNOSIS AND TESTING or DIAGNOSIS AND TESTING .
POOR SDAR AUDIO RECEPTION	1. SDAR antenna Inoperative.	Perform the "Poor or No Satellite Audio Reception" test. Refer to POOR OR NO SATELLITE AUDIO RECEPTION .
SOUND DISTORTION (VIBRATION FROM SPEAKER AREA, BUZZING - HUMMING)	1. Door trim panel loose or missing fasteners.	Inspect door trim panel and correct as necessary. Replace any missing fasteners.
	2. Water shield loose or misaligned.	Inspect water shield and adjust as required.
	3. Items placed in door trim panel map pockets vibrating or moving from side to side.	Remove items from door trim panel. Ensure that vibration is no longer present.

DIAGNOSIS AND TESTING > POOR OR NO AM/FM AUDIO RECEPTION

For a complete wiring diagram, refer to appropriate **SYSTEM WIRING DIAGRAMS** article .

DIAGNOSIS AND TESTING > POOR OR NO AM/FM AUDIO RECEPTION > POSSIBLE CAUSES

Possible Causes
ANTENNA CONNECTION

OPEN OR SHORTED ANTENNA CABLE
ANTENNA
RADIO

DIAGNOSIS AND TESTING > POOR OR NO AM/FM AUDIO RECEPTION > DIAGNOSTIC TEST

1. CHECK THE ANTENNA CONNECTION

1. Turn the ignition off.
2. Disconnect the Radio C3 harness connector.
3. Inspect the Audio Antenna harness connection.

Is the Antenna connection clean and secure?

Yes

1. Go To 2

No

1. Repair the Antenna connection as needed.
2. Perform the BODY VERIFICATION TEST. Refer to STANDARD PROCEDURE .

2. RADIO

1. Connect the (special tool #9977-6-FM, Antenna) to the Radio C3 component connector.
2. Place the test antenna base on the roof of the vehicle.
3. Turn the ignition on.
4. Drive the vehicle outside to an un-obstructed area.
5. Turn the Radio on and select several different known good stations from the AM and FM bands.
6. Note any of the following type of reception concerns being heard:
 1. Silence
 2. Static
 3. Noise
 4. Popping
 5. Screeching
 6. Hissing

7. Crackling
8. Humming
9. Weak Signal
10. Interference
11. Motor Sound

Is the audio reception still poor or not available?

Yes

1. Replace the Radio in accordance with the Service Information.
2. Perform the BODY VERIFICATION TEST. Refer to STANDARD PROCEDURE .

No

1. Go To 3

3. ANTENNA

1. Turn the ignition off.
2. Reconnect the Radio C3 harness connector.
3. Disconnect the Radio Antenna harness connector.
4. Connect the (special tool #9977-6-FM, Antenna) to the Radio Antenna harness connector.
5. Turn the Radio on and select several different known good stations from the AM and FM bands.
6. Note any of the following type of reception concerns being heard:
 1. Silence
 2. Static
 3. Noise
 4. Popping
 5. Screeching
 6. Hissing
 7. Crackling
 8. Humming
 9. Weak Signal
 10. Interference
 11. Motor Sound

Is the audio reception still poor or not available?

Yes

1. Go To 4

No

1. Replace the Radio Antenna in accordance with the Service Information.
2. Perform the BODY VERIFICATION TEST. Refer to STANDARD PROCEDURE .

4. ANTENNA CABLE

Fig 1: Special Tool Jumper & Antenna Harness Connector

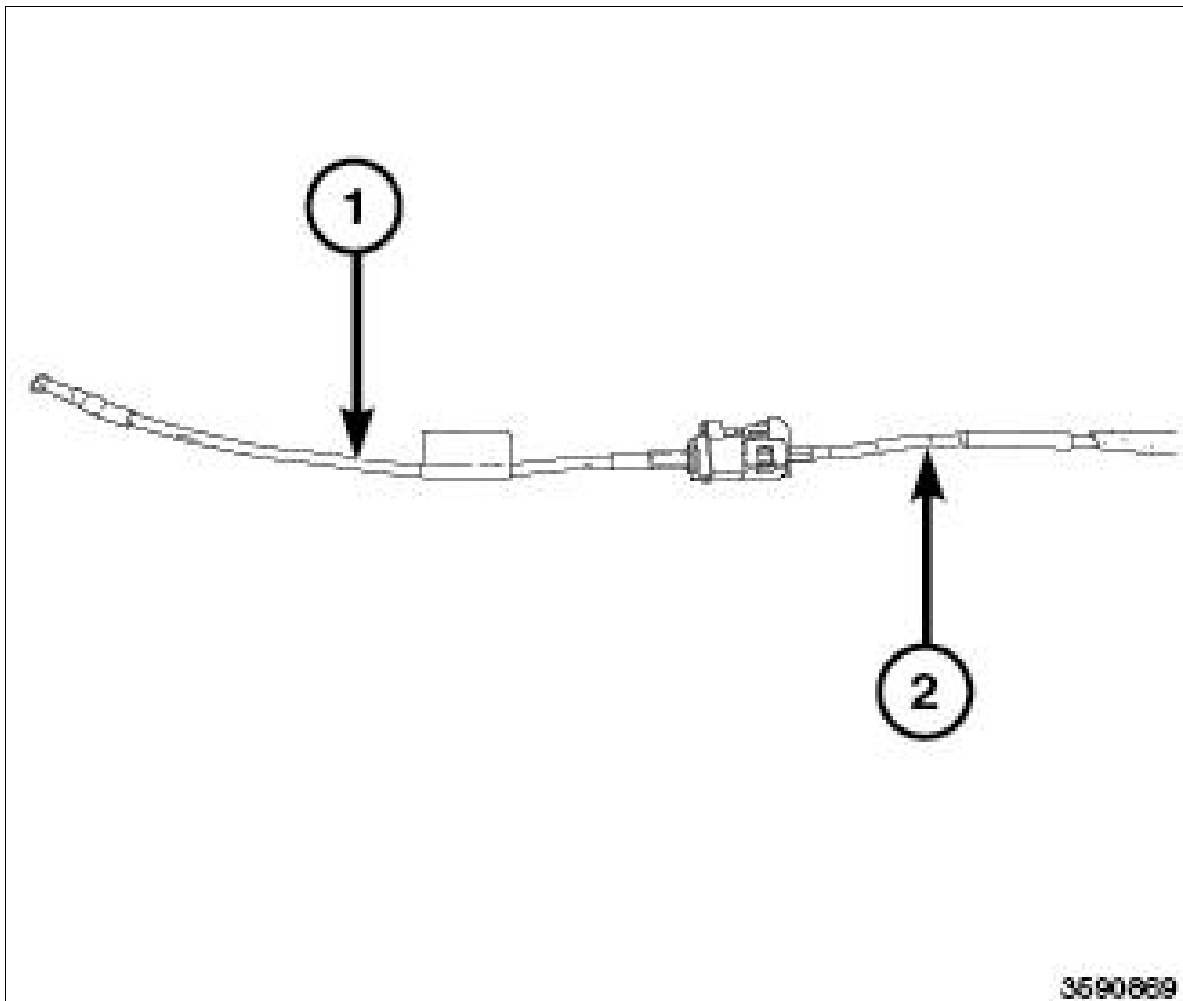

Courtesy of CHRYSLER GROUP, LLC

1. Turn the ignition off.
2. Disconnect the (special tool #9977-6-FM, Antenna) from the Radio Antenna harness connector.
3. Connect the appropriate (special tool #9977-6-4, Jumper) (1) or (special tool #9977-6-2, Jumper) (1) to the Radio Antenna harness connector (2) at the Antenna.

Fig 2: Special Tool, Antenna Harness Connector & DVOM

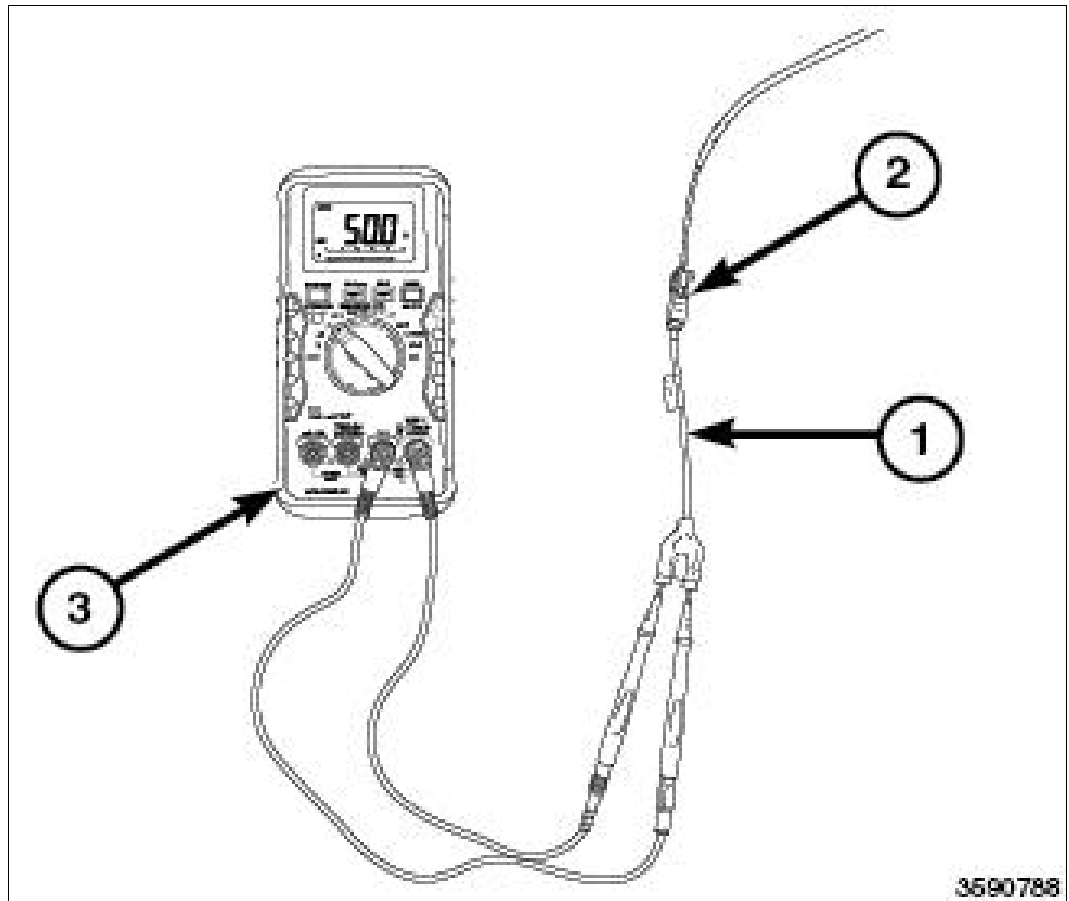

Courtesy of CHRYSLER GROUP, LLC

4. Disconnect the Radio C3 harness connector.
5. Connect the appropriate (special tool #9977-6-1, Adapter) (1) or (special tool #9977-6-3, Adapter) (1) to the Radio C3 harness connector (2).
6. Measure the resistance across the tool terminals.

Is the resistance between 47.5 and 52.5 Ohms?

Yes

1. The source of the poor reception is not caused by the Radio, Antenna Cable or Radio Antenna.
2. Perform the BODY VERIFICATION TEST. Refer to STANDARD PROCEDURE .

No

1. Replace the Antenna Cable in accordance with the Service Information.
2. Perform the BODY VERIFICATION TEST. Refer to STANDARD PROCEDURE .

For a complete wiring diagram, refer to appropriate **SYSTEM WIRING DIAGRAMS** article .

DIAGNOSIS AND TESTING > POOR OR NO SATELLITE AUDIO RECEPTION > POSSIBLE CAUSES

Possible Causes
SATELLITE AUDIO ANTENNA CONNECTION
OPEN OR SHORTED SATELLITE AUDIO ANTENNA
SATELLITE AUDIO ANTENNA
RADIO

DIAGNOSIS AND TESTING > POOR OR NO SATELLITE AUDIO RECEPTION > DIAGNOSTIC TEST

1. CHECK THE ANTENNA CONNECTION

1. Turn the ignition off.
2. Disconnect the Radio C6 harness connector.
3. Inspect the Satellite Audio Antenna harness connection.

Is the Antenna connection clean and secure?

Yes

1. Go To 2

No

1. Repair the Satellite Audio Antenna connection as needed.
2. Perform the BODY VERIFICATION TEST. Refer to STANDARD PROCEDURE .

2. RADIO

1. Connect the (special tool #9977-6-SAT, Antenna) (1) to the Radio C6 component connector.
2. Place the test antenna base on the roof of the vehicle.
3. Turn the ignition on.
4. Drive the vehicle outside to an un-obstructed area.
5. Turn the Satellite Radio on and select several different known good stations.

Is the reception still poor or not available?

Yes

1. Replace the Radio in accordance with the Service Information.
2. Perform the BODY VERIFICATION TEST. Refer to STANDARD PROCEDURE .

No

1. Go To 3

3. ANTENNA

1. Turn the ignition off.
2. Reconnect the Radio C6 harness connector.
3. Disconnect the Satellite Audio Antenna harness connector.
4. Connect the (special tool #9977-6-SAT, Antenna) (1) to the Satellite Audio Antenna harness connector (2).
5. Turn the Satellite Radio on and select several different known good stations.

Is the reception still poor or not available?

Yes

1. Go To 4

No

1. Replace the Satellite Audio Antenna in accordance with the Service Information.
2. Perform the BODY VERIFICATION TEST. Refer to STANDARD PROCEDURE .

4. ANTENNA CABLE

Fig 1: Special Tool Jumper & Antenna Harness Connector

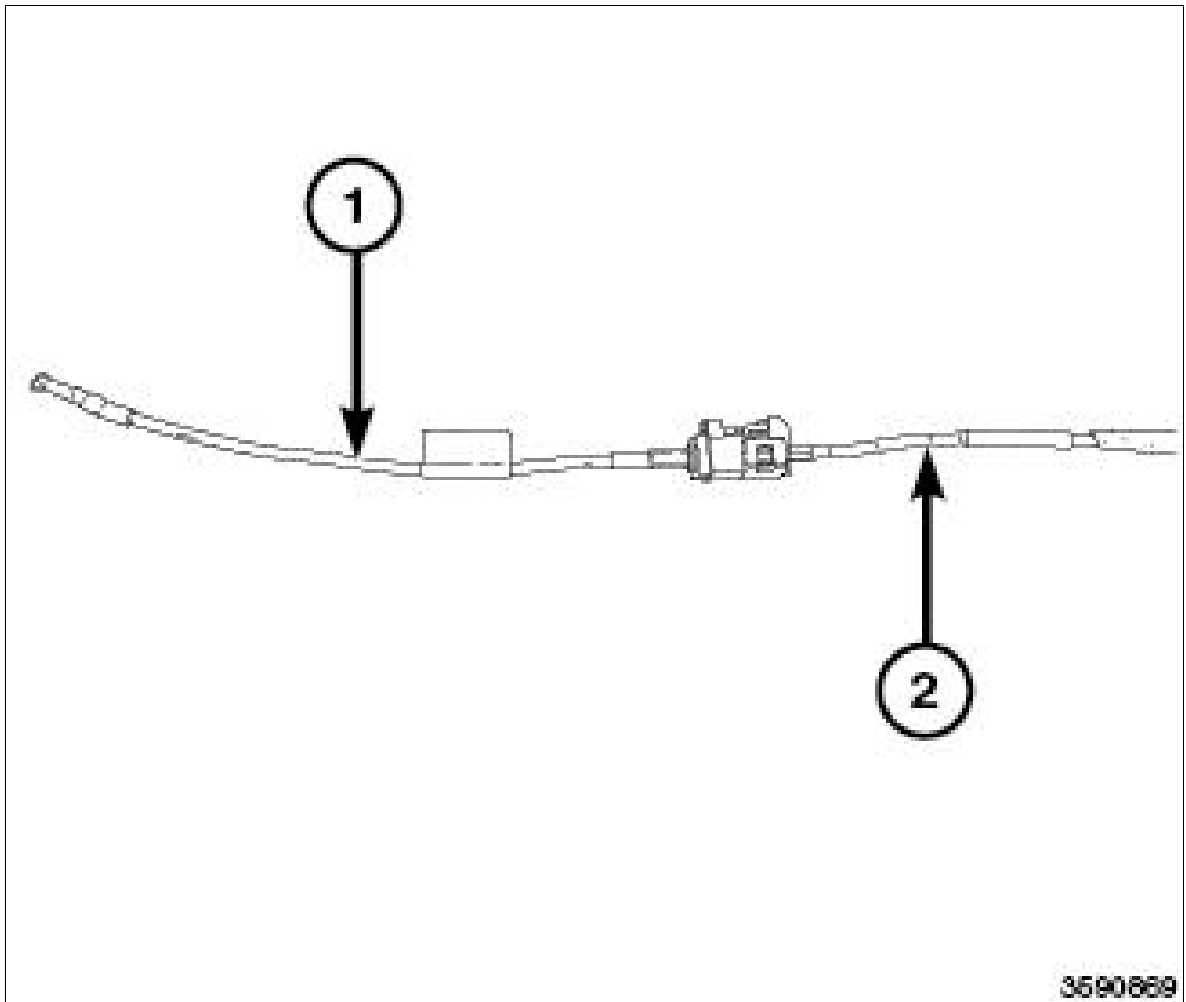

Courtesy of CHRYSLER GROUP, LLC

1. Turn the ignition off.
2. Disconnect the (special tool #9977-6-SAT, Antenna) from the Satellite Audio Antenna harness connector.
3. Connect the appropriate (special tool #9977-6-4, Jumper) (1) or (special tool #9977-6-2, Jumper) (1) to the Satellite Audio Antenna harness connector (2) at the Antenna.

Fig 2: Special Tool, Antenna Harness Connector & DVOM

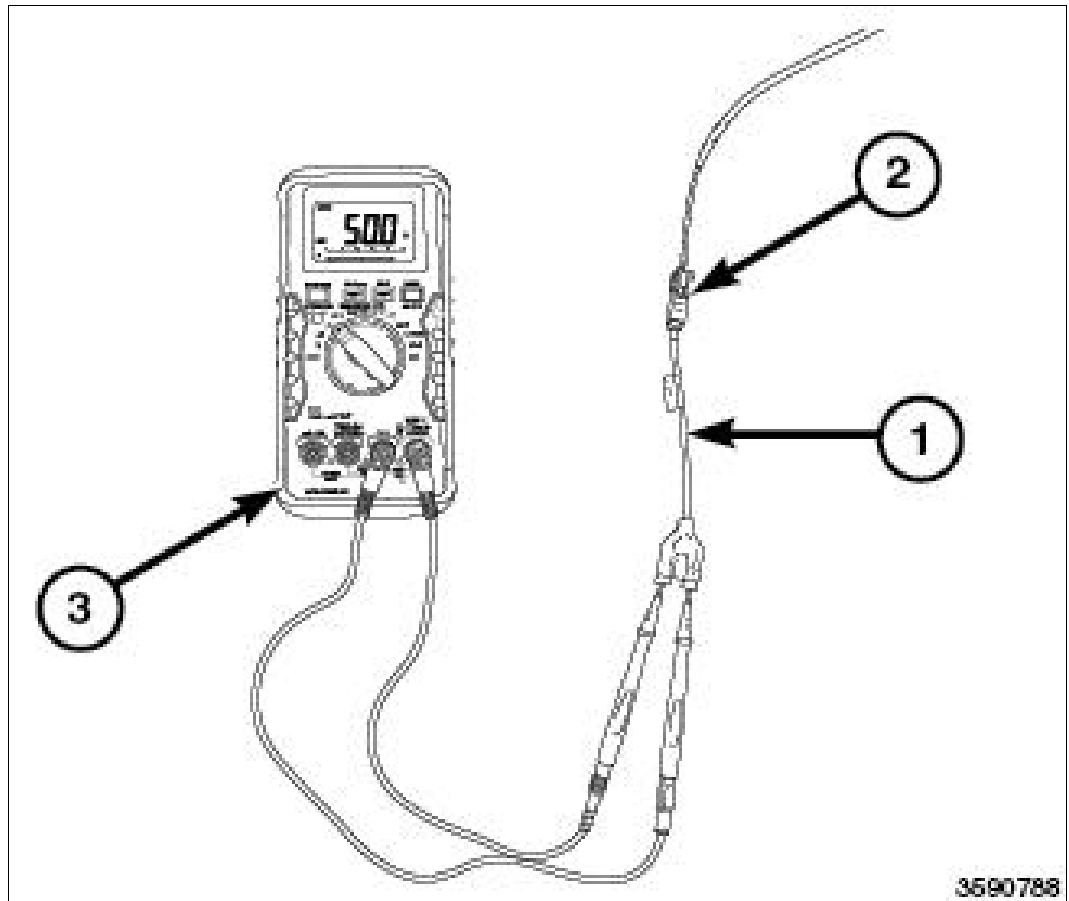

Courtesy of CHRYSLER GROUP, LLC

4. Connect the appropriate (special tool #9977-6-1, Adapter) (1) or (special tool #9977-6-3, Adapter) (1) to the Radio C6 harness connector (2).
5. Measure the resistance across the tool terminals.

Is the resistance between 47.5 and 52.5 Ohms?

Yes

1. The source of the poor reception is not caused by the Radio, Satellite Antenna Cable or Satellite Antenna.
2. Perform the BODY VERIFICATION TEST. Refer to STANDARD PROCEDURE .

No

1. Replace the Satellite Audio Antenna Cable in accordance with the Service Information.
2. Perform the BODY VERIFICATION TEST. Refer to STANDARD PROCEDURE .

DIAGNOSIS AND TESTING > POOR OR NO CELLULAR RECEPTION

For a complete wiring diagram, refer to appropriate **SYSTEM WIRING DIAGRAMS** article .

DIAGNOSIS AND TESTING > POOR OR NO CELLULAR RECEPTION > POSSIBLE CAUSES

Possible Causes
CELLULAR ANTENNA CONNECTION
OPEN OR SHORTED CELLULAR ANTENNA CABLES
OPEN OR SHORTED CELLULAR ANTENNA
CELLULAR ANTENNA
RADIO

DIAGNOSIS AND TESTING > POOR OR NO CELLULAR RECEPTION > DIAGNOSTIC TEST

1. CHECK THE ANTENNA CONNECTION

1. Turn the ignition off.
2. Disconnect the Radio C7 harness connector.
3. Inspect the Cellular Antenna harness connection.

Is the Antenna connection clean and secure?

Yes

1. Go To 2

No

1. Repair the Cellular Antenna connection as needed.
2. Perform the BODY VERIFICATION TEST. Refer to STANDARD PROCEDURE .

2. RADIO

1. (special tool #9977-6-CELL, Adapter, Cellular Antenna Diagnostic) Connect the (1) to the Radio C7 component connector.
2. Place the test antenna base on the roof of the vehicle.
3. Turn the ignition on.
4. Drive the vehicle outside to an un-obstructed area.
5. Turn the Radio on.

Is the reception still poor or not available?

Yes

1. Replace the Radio in accordance with the Service Information.
2. Perform the BODY VERIFICATION TEST. Refer to STANDARD PROCEDURE .

No

1. Go To 3

3. ANTENNA

1. Turn the ignition off.
2. Reconnect the Radio C7 harness connector.
3. Disconnect the Cellular Antenna harness connector.
4. Connect the (special tool #9977-6-CELL, Adapter, Cellular Antenna Diagnostic) (1) to the Radio C7 component connector.
5. Turn the Radio on and select several different known good APP/ Cellular functions.

Is the reception still poor or not available?

Yes

1. Go To 4

No

1. Replace the Cellular Antenna in accordance with the Service Information.
2. Perform the BODY VERIFICATION TEST. Refer to STANDARD PROCEDURE .

4. ANTENNA CABLE

Fig 1: Special Tool Jumper & Antenna Harness Connector

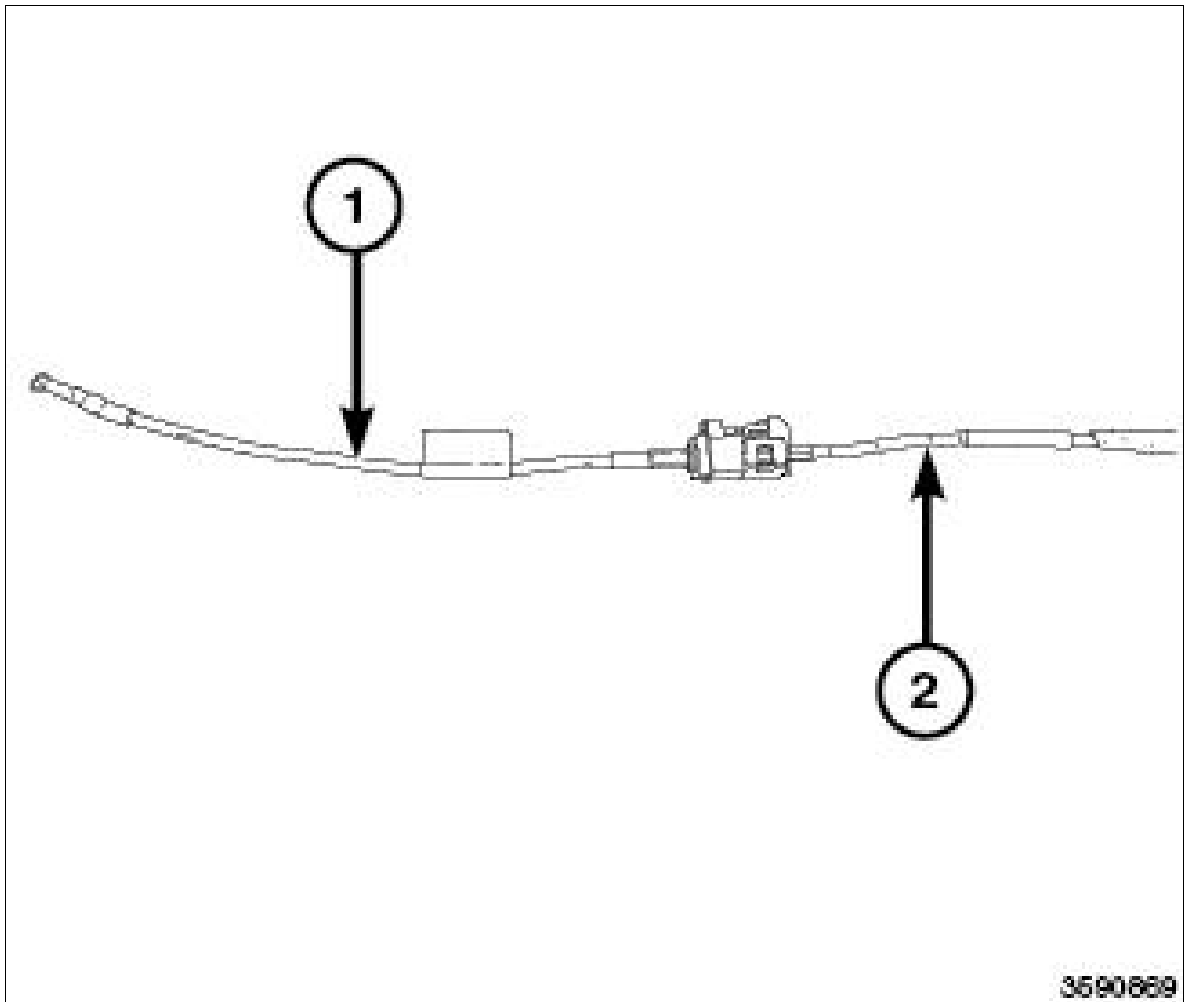

Courtesy of CHRYSLER GROUP, LLC

1. Turn the ignition off.
2. Connect the (special tool #9977-6-CELL, Adapter, Cellular Antenna Diagnostic) (1) to the Radio C7 component connector.
3. Connect the appropriate (special tool #9977-6-4, Jumper) (1) or (special tool #9977-6-2, Jumper) (1) to the Cellular Antenna harness connector (2) at the Antenna.

Fig 2: Special Tool, Antenna Harness Connector & DVOM

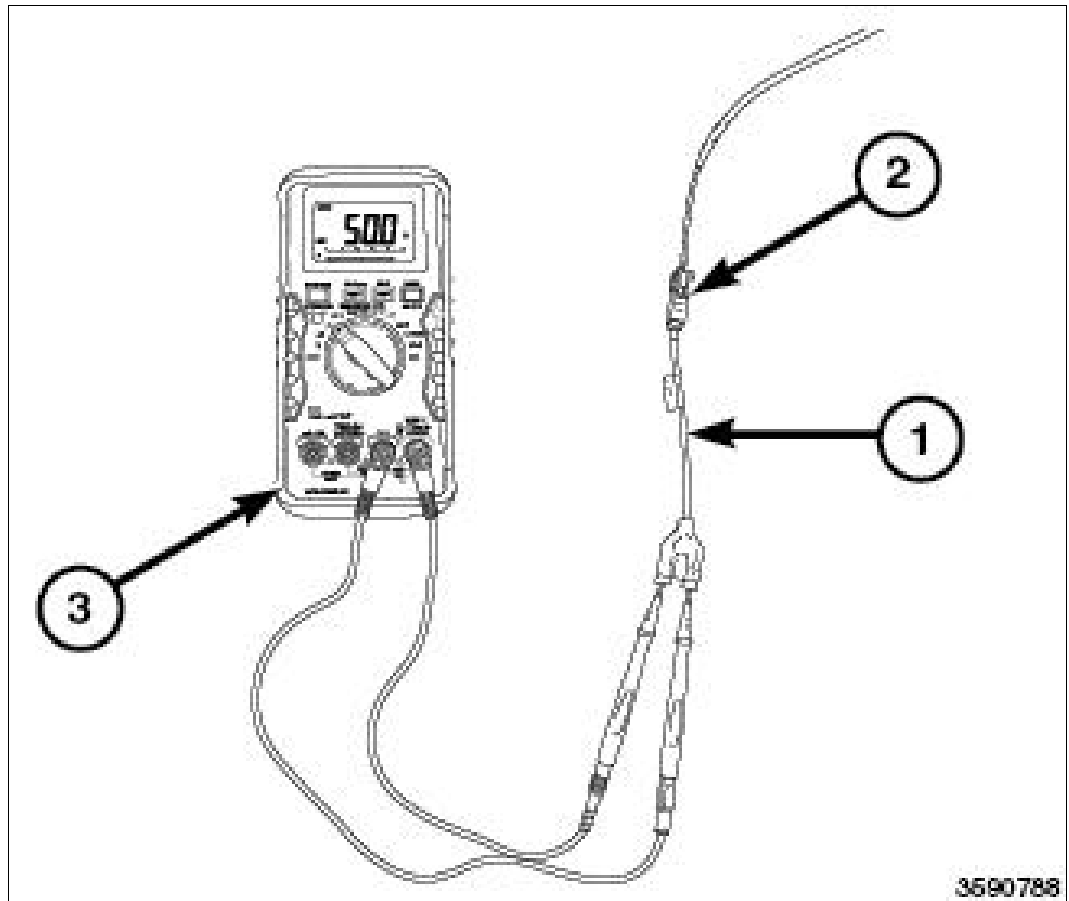

Courtesy of CHRYSLER GROUP, LLC

4. Connect the appropriate (special tool #9977-6-1, Adapter) (1) or (special tool #9977-6-3, Adapter) (1) to the Radio C7 harness connector (2).
5. Measure the resistance across the tool terminals.

Is the resistance between 47.5 and 52.5 Ohms?

Yes

1. The source of the poor reception is not caused by the Radio, Cellular Antenna Cable or Cellular Antenna.
2. Perform the BODY VERIFICATION TEST. Refer to STANDARD PROCEDURE .

No

1. Replace the Cellular Antenna Cable in accordance with the Service Information.
2. Perform the BODY VERIFICATION TEST. Refer to STANDARD PROCEDURE .

DIAGNOSIS AND TESTING > POOR OR NO GPS RECEPTION

For a complete wiring diagram, refer to appropriate **SYSTEM WIRING DIAGRAMS** article .

DIAGNOSIS AND TESTING > POOR OR NO GPS RECEPTION > POSSIBLE CAUSES

Possible Causes
GPS ANTENNA CONNECTION
OPEN OR SHORTED GPS ANTENNA CABLES
OPEN OR SHORTED GPS ANTENNA
GPS ANTENNA
RADIO

DIAGNOSIS AND TESTING > POOR OR NO GPS RECEPTION > DIAGNOSTIC TEST

1. CHECK THE ANTENNA CONNECTION

1. Turn the ignition off.
2. Disconnect the Radio C6 harness connector.
3. Inspect the GPS Antenna harness connection.

Is the Antenna connection clean and secure?

Yes

1. Go To 2

No

1. Repair the GPS Antenna connection as needed.
2. Perform the BODY VERIFICATION TEST. Refer to STANDARD PROCEDURE .

2. RADIO

1. Connect the (special tool #9977-6-GPS, Adapter, GPS Antenna Diagnostic) (1) to the Radio C6 component connector.
2. Place the test antenna base on the roof of the vehicle.
3. Turn the ignition on.
4. Drive the vehicle outside to an un-obstructed area.
5. Turn the Satellite Radio on and select several different known good stations.

Is the reception still poor or not available?

Yes

1. Replace the Radio in accordance with the Service Information.

2. Perform the BODY VERIFICATION TEST. Refer to STANDARD PROCEDURE .

No

1. Go To 3

3. ANTENNA

1. Turn the ignition off.

2. Reconnect the Radio C6 harness connector.

3. Disconnect the GPS Antenna harness connector.

4. Connect the (special tool #9977-6-GPS, Adapter, GPS Antenna Diagnostic) (1) to the Radio C6 component connector.

5. Turn the Radio on.

Is the reception still poor or not available?

Yes

1. Go To 4

No

1. Replace the GPS Antenna in accordance with the Service Information.

2. Perform the BODY VERIFICATION TEST. Refer to STANDARD PROCEDURE .

4. ANTENNA CABLE